

Vinyl Siding Institute

INSTALLATION MANUAL



This manual is published by the Vinyl Siding Institute, Inc. (VSI) as a service to the industry. VSI members are manufacturers of vinyl siding and other polymeric siding and suppliers to the industry. The information provided in this publication is offered in good faith and believed to be reliable, but is made without warranty, express or implied, as to merchantability, fitness for a particular purpose, or any other matter. VSI does not endorse the proprietary products or processes of any manufacturer.

This publication is not intended to provide specific advice, legal or otherwise, on particular products or processes. Readers should consult with their own legal and technical advisors, vinyl siding suppliers, and other appropriate sources (including but not limited to product or package labels, technical bulletins, or sales literature) that contain information about known and reasonably foreseeable health and safety risks of their proprietary products and processes. VSI, its members, and contributors do not assume any responsibility for the users' compliance with applicable laws and regulations, nor for any persons relying on the information contained in this guide.

Information about individual manufacturers' products contained herein has been provided by those manufacturers, who are solely responsible for the accuracy and completeness of the data.

Use of Manufacturers' Instructions

Some specialized products may require unique installation instructions. Please contact the manufacturer directly for information about installing those products.



Vinyl siding is engineered for easy installation. To make the process even easier, get help through every step with our full vinyl siding installation videos at vinylsiding.org/installation. Videos are available in additional languages.

For general information about vinyl siding, contact the Vinyl Siding Institute at:



Vinyl Siding Institute
1800 Diagonal Road, Suite 545
Alexandria, VA 22314
vinylsiding.org

Build the life you want

BECOME A VSI CERTIFIED VINYL SIDING INSTALLER

Want to increase your skill level and receive marketing materials that will help improve your professional presence and grow your business? Register for a VSI Certified Installer class, in-person or online.

Questions? Contact us at VSIsupport@databanque.com or call us at 877-627-8997 to find out more.



NOTE: Vinyl siding installers with the required experience levels can become VSI Certified Installers if they successfully complete a course and pass a written examination. Certified Installers receive an identification badge and are listed on VSI's website. For more information on the VSI Certified Installer Program, visit vinylsiding.org.



TABLE OF CONTENTS

Foreword	1	Horizontal Siding Installation	21
Important Notes	2	Installing Panels.....	21
Building Codes.....	2	Fitting Siding Around Fixtures.....	22
Installing for Wind Load Resistance	3	Fitting Under Windows	22
Water-Resistive Barrier	3	Sidewall Flashing at Roof Lines	23
Storage.....	4	Finishing at the Top of Walls	24
Fire Safety Information	4	Optional Eave and Gable Treatment.....	26
Re-siding Over Asbestos Siding.....	4	Vertical Siding and Accessories Installation	27
Historic Restoration	4	Preparation.....	27
Disposal/Recycling	4	Accessories.....	27
Basic Installation Rules	5	Window, Door, and Roof Trim	28
Cleanup.....	6	Sidewalls.....	28
Materials, Tools, and Accessories	7	Gable Ends.....	30
Panel Profiles.....	7	Specialty Siding.....	30
Basic Installation Tools and Equipment.....	7	Soffit Installation	30
Specialty Tools.....	8	Gable Peak Preparation	31
Accessories.....	8	Preparation.....	31
Getting Started	9	Installation Over Open Eaves.....	32
Wall Substrate Materials.....	9	Installation Over Enclosed Eaves	34
How to Measure	10	Porch Ceilings	35
Estimating Worksheet	11	Other Recommendations	36
Fastener Choices	12	Attaching Shutters and	
Nails	12	Other Specialty Products.....	36
Fastening Procedure	13	Replacing a Damaged Panel.....	36
Cutting Siding	14	Repairing a Damaged Corner Post	37
Preparing the Walls	15	Bending Trim Sheet.....	38
Installing Accessories	16	Using Drawings	38
Starter Strip	17	Measuring	39
Windows, Doors, and Roof Lines	18	Cutting and Bending.....	40
J-Channel Over Roof Lines.....	20	Attaching Trim Sheet.....	40
Gable and Trim.....	20	Installing Trim with Built In	
		J-Channel Around Windows	40
		Terms to Know Appendix 1	4 1
		Acronyms Appendix 2	43
		Notes	44

FOREWORD

Known for its outstanding performance, vinyl siding is the exterior cladding of choice for homeowners, remodeling contractors, architects, and builders. Compared to other siding products, vinyl is attractive, durable, easy to maintain, and cost-effective. Vinyl siding is available in a variety of architectural styles, eye-catching colors, and design-enhancing profiles, finishes, and textures.

To ensure proper quality, vinyl siding must meet or exceed the requirements of ASTM D3679 Standard Specification for Rigid Poly (Vinyl Chloride) (PVC) Siding and other applicable standards from ASTM International, including those regarding color retention. As a service to the industry, the Vinyl Siding Institute (VSI) sponsors a program that allows manufacturers to certify, with independent, third-party verification, that their siding meets or exceeds this specification. The program covers vinyl siding, as well as polypropylene siding (certified to meet or exceed ASTM D7254) and insulated vinyl siding (certified to meet or exceed ASTM D7793). Insulated vinyl siding is a type of continuous insulation that provides a minimum R-value of R-2.0. Insulated vinyl siding is widely accepted in energy efficiency programs and is defined in the International Energy Conservation Code. For a listing of certified products, see VSI's website at vinylsiding.org. In addition, look for the appropriate certification labels on boxes of siding (Figure 1).

This manual sets forth the basic guidelines for vinyl siding installation. The instructions herein are based, in part, on ASTM D4756 Standard Practice for Installation of Rigid Poly (Vinyl Chloride) (PVC) Siding and Soffit, the standard method for installation of vinyl siding and soffit. Updated information has been added as necessary. Additionally, it is recommended that installers review local building codes and manufacturers' literature for variations that may apply to specific products and/or geographic areas. The siding manufacturer's specific product installation instructions should be followed in the event of a conflict with general industry practice or guidance.

The method of applying vinyl siding and soffit is essentially the same for new construction and re-siding. However, where there are differences, special instructions for new construction and re-siding are included, as well as recommendations for historic restoration projects. In all applications, care should be exercised to properly prepare the structure. See the Basic Installation Rules and additional details throughout this manual for proper installation techniques.

Polypropylene siding is an exterior cladding similar to vinyl siding; it should be installed according to the manufacturer's instructions, as well as applicable local building codes in your area.

While this installation manual reflects generally accepted vinyl siding installation practices at the time of publication, because of continuing advances in design and materials, it is particularly important to check manufacturer literature and current building code requirements for your area.



Figure 1

BUILDING CODES

Installers need to be aware of building code requirements in the geographic areas where they are installing, and how the codes relate to the instructions given in this manual and by the siding manufacturer. The requirements of local building codes must always be observed, because they represent the legal requirements for an installation in a given jurisdiction. However, local codes are based on the national model building codes. Model codes themselves do not have the force of law until they are adopted by a state or local jurisdiction. In the United States, the primary source of model codes is the International Code Council, which publishes the International Building Code (IBC), International Residential Code (IRC), and International Energy Conservation Code (IECC). In Canada, the primary model code is the National Building Code of Canada (NBC), published by the National Research Council of Canada.

Most of the model building codes, and thus the local codes based on them, recognize that the product manufacturer usually knows how its product should be installed in order to provide best performance. Therefore, most building codes reference the manufacturer's instructions and state that the product must be installed according to the code and the manufacturer's instructions. However, any specific requirement in a local code will usually override any provision of the manufacturer's instructions, especially if the local requirement is more restrictive. Therefore, vinyl siding installations must always conform to local building codes, but the local code may also require that the installation conform to the siding manufacturer's instructions.

The codes provide the greatest recognition to products that have been certified to a recognized standard by an approved quality control agency. In fact, current editions of the IBC and IRC model codes require vinyl siding to be certified to ASTM D3679, polypropylene siding be certified to ASTM D7254, insulated vinyl siding be certified to ASTM D7793 (IRC only), and all to be verified by an approved quality control agency. As relevant editions of the model codes are adopted by local jurisdictions, code officials will want to verify that the siding is properly certified (which can usually be determined by identifying the VSI certified product label on the box—see Figure 1 and that the installation conforms to the manufacturer's instructions. Always be sure that the instructions are available on the job site for an inspector to review.

This manual is not a building code and it is not a substitute for the manufacturer's instructions. However, it has been developed by referencing the provisions of the model building codes, the requirements of ASTM D4756, and generally accepted installation practices within the vinyl siding industry. This manual therefore reflects the most common installation requirements that apply to the vast majority of vinyl siding products. Use this manual to understand how vinyl siding and soffit should generally be installed, but be prepared to comply with any differing provisions of local codes and the manufacturer's instructions for a specific product.

INSTALLING FOR WIND LOAD RESISTANCE

Vinyl siding is remarkably resistant to high wind, given its light weight and relatively simple installation. But in order for it to perform to its potential, it must first be properly selected, and then properly installed.

All certified vinyl siding is tested for wind load resistance and must meet certain minimum requirements. All polymeric claddings certified under the VSI program are required to include standard design pressure rating for wind load labeling on either product itself or the packaging. The labeling shows the wind “performance-ability” of the products, so that code officials and other experts know that these are the right products for use in any given area. Be sure to consult with Architects, Code Officials or Building/Site Engineers about the design pressure rating required for the building prior to starting installation.

Vinyl siding installers need to make sure that the siding is installed in a way that allows it to meet its rating. The instructions in this manual provide the minimum requirements for most vinyl siding products for most installation situations. However, the manufacturer may have different instructions for their products, or they may have their own special installation requirements that apply in high-wind locations. Always consult the manufacturer’s instructions before starting a vinyl siding installation.

Design pressure testing has been in effect for the past 20+ years, but in recent years, testing has distinguished between coastal and non-coastal products with even more rigorous standards. Polymeric siding has improved its resilience in direct relationship with code requirements and standards becoming more stringent. **For more detailed information on installing product in high wind coastal areas, please request a copy of How to Properly Install Polymeric Siding and Soffit in Coastal Areas.**

WATER-RESISTIVE BARRIER

Vinyl siding, insulated vinyl siding, and polypropylene siding are exterior claddings, not water-resistive barriers, and are designed to allow the material underneath to breathe. This factor provides a supplemental rainscreen that reduces the amount of water that reaches an underlying water-resistive barrier.

To achieve designed performance, and to comply with the most recent building codes, vinyl siding, insulated vinyl siding, and polypropylene siding must be installed over a water-resistive barrier, which is intended to prevent liquid water that has penetrated behind the exterior covering from further intruding into the exterior wall assembly.

Water-resistive barrier systems often consist of a combination of exterior cladding such as vinyl siding, insulated vinyl siding or polypropylene siding, flashed wall openings and penetrations, water-resistive barrier material, and sheathing. Effective exterior wall systems will shed the water initially, control moisture flow by capillary and diffusion action, and minimize absorption into the wall structure.

The level of water resistance required is determined by the applicable building code, the structure, and the climate. If correctly installed as required by code, certified polymeric siding can effectively withstand the elements. To find out more about I-CODE regulations, please request a current in-depth I-CODE guide from VSI. Note that additional measures may provide increased protection against water intrusion than the minimum requirements of the building code.

STORAGE

When transporting vinyl siding to a job site, make certain to keep the cartons flat and supported along their entire length. **At the job site, take the following precautions when storing vinyl siding cartons:**

- Store the cartons on a flat surface and support the entire length of the cartons.
- Keep the cartons dry.
- Store the cartons away from areas where falling objects or other construction activity may cause damage.
- Do not store the cartons in stacks more than six boxes high, and make sure the stacks are stable.
- Do not store the cartons in any location where temperatures may exceed 130° F/54.4° C (e.g., on blacktop pavement during unusually hot weather or under dark tarps or plastic wraps without air circulation).

FIRE SAFETY INFORMATION

Vinyl siding is composed mainly of polyvinyl chloride, more commonly known as vinyl or PVC. Due to its chlorine base, vinyl siding is inherently flame-retardant. So, when it comes to fire safety, vinyl siding is a recognized material that meets or exceeds industry standards. All building materials should be installed in accordance with local and state building code requirements.

Please see the most recent Fire Safety fact sheet for more information.

RE-SIDING OVER ASBESTOS SIDING

Asbestos siding is a regulated material, and the appropriate environmental agency or local building code official should be contacted before re-siding over this product.

HISTORIC RESTORATION

When using vinyl siding for historic restoration, please follow the historic governing commission's recommendations on all requirements. Additionally, please review the siding manufacturer's instructions and your local building codes for variations that may apply.

DISPOSAL/RECYCLING

Dispose of all scrap or excess material in a manner that is consistent with local and state rules and regulations. PVC is a thermoplastic material that can be recycled; for more information, contact the siding distributor or manufacturer about the availability of recycling programs.

BASIC INSTALLATION RULES

Before getting started, it is important to review several rules of thumb for vinyl siding application. The following rules, which are repeated in this guide, are critical for proper vinyl siding installation:

1. Installed panels and accessories must move freely from side to side.
2. When installing a siding panel, push up from the bottom until the lock is fully engaged with the piece below it. Without stretching the panel, reach up and fasten it into place.
3. Fasten nails or other fasteners in the center of the nailing slots (see Figure 15).
4. Do not force the panels up or down when fastening in position.
5. Do not drive the head of the fastener tightly against the siding nail hem. Allow approximately 1/32" (0.8mm) (about the thickness of a dime) clearance between the fastener head and the siding panel. Make sure the panels can move freely back and forth. Drive fasteners straight and level to prevent distortion and buckling of the panel.
6. Leave a minimum of 1/4" (6.4mm) clearance at all openings and stops to allow for normal expansion and contraction. When installing in temperatures below 40° F/4.4° C, increase minimum clearance to 3/8" (9.5mm).
7. Do not caulk the panels where they meet the receiver of inside corners, outside corners, or J-trim. Do not caulk the overlap joints.
8. Do not face-nail or staple through siding, except in very limited applications where the nail hem is removed and nail punch lock systems cannot be used. Vinyl siding expands and contracts with outside temperature changes. Face-nailing can result in ripples in the siding.
9. In re-siding, furring or removal of uneven original siding may be necessary; take appropriate actions to ensure a smooth and continuous surface.
10. In new construction, avoid the use of green lumber as the underlayment. Keep in mind that siding can only be as straight and stable as what lies under it.
11. The installation of specific products may differ in detail from the instructions given in this manual. Always follow the manufacturer's instructions, using parts specified by the manufacturer, to ensure proper installation.

CLEANUP

The beauty of vinyl siding is maintained with little effort. Although vinyl siding will get dirty, like anything exposed to the atmosphere, a heavy rain will do wonders to clean it. It's also possible to wash it down with an ordinary garden hose. If neither rain nor hosing does a satisfactory job, follow these simple instructions:

1. Use an ordinary, long-handled car washing brush. This brush has soft bristles, and the handle fastens onto the end of the hose. It allows the siding to be washed just like a car. Avoid using stiff bristle brushes or abrasive cleaners, which may change the gloss of the cleaned area and cause the siding to look splotchy.
2. To remove soot and grime found in industrial areas, wipe down the siding with a solution made up of the following:
 - 1/3 cup (0.08 liter) powder detergent (e.g., Fab[®], Tide[®], or equivalent powder detergent)*
 - 2/3 cup (0.16 liter) powder household cleaner (e.g., Soilax[®], Spic & Span[®], or equivalent)*
 - 1 gallon (3.8 liters) water
3. If mildew is a problem, use the solution previously mentioned, but add 1 quart (0.95 liter) liquid laundry bleach.
4. When washing down the entire house, start at the bottom and work up to the top in order to prevent streaking.
5. **For stubborn stains, use the following chart:**

STAIN	CLEANERS*
Bubble Gum	Fantastik [®] , Murphy's Oil Soap [®] , or solution of vinegar (30 percent) and water (70 percent)
Crayon	Lestoil [®]
DAP (Oil-based caulk)	Fantastik [®]
Felt-tip Pen	Fantastik [®] or water-based cleaners
Grass	Fantastik [®] , Lysol [®] , Murphy's Oil Soap [®] , or Windex [®]
Lipstick	Fantastik [®] or Murphy's Oil Soap [®]
Lithium Grease	Fantastik [®] , Lestoil [®] , Murphy's Oil Soap [®] , or Windex [®]
Mold and Mildew	Fantastik [®] or solution of vinegar (30 percent) and water (70 percent)
Motor Oil	Fantastik [®] , Lysol [®] , Murphy's Oil Soap [®] , or Windex [®]
Oil	Soft Scrub [®]
Paint	Brillo [®] Pad or Soft Scrub [®]
Pencil	Soft Scrub [®]
Rust	Fantastik [®] , Murphy's Oil Soap [®] , or Windex [®]
Tar	Soft Scrub [®]
Top Soil	Fantastik [®] , Lestoil [®] , or Murphy's Oil Soap [®]

*Cleaning materials are listed in alphabetical order.

VSI does not endorse proprietary products or processes and makes no warranties for the products referenced herein. Reference to proprietary names is for illustrative purposes only and is not intended to imply that there are not equally effective alternatives.

Follow the precautionary labeling instructions on the cleaning agent container.
Protect shrubs from direct contact with cleaning agents.

MATERIALS, TOOLS, AND ACCESSORIES

PANEL PROFILES

Vinyl siding comes in a variety of shapes, textures, and colors, creating a wide array of looks for different houses. It is manufactured primarily from durable polyvinyl chloride in several different profiles, including single, double, triple, vertical, and Dutch lap (Figure 2).

There are also various types of vinyl soffit (the material used to enclose the underside of an eave or overhang). Soffit can be vented, solid, hidden vent, or a combination of solid and vented (Figure 3) and is designed to maximize airflow, preventing moisture accumulation and heat buildup between the siding and the house.

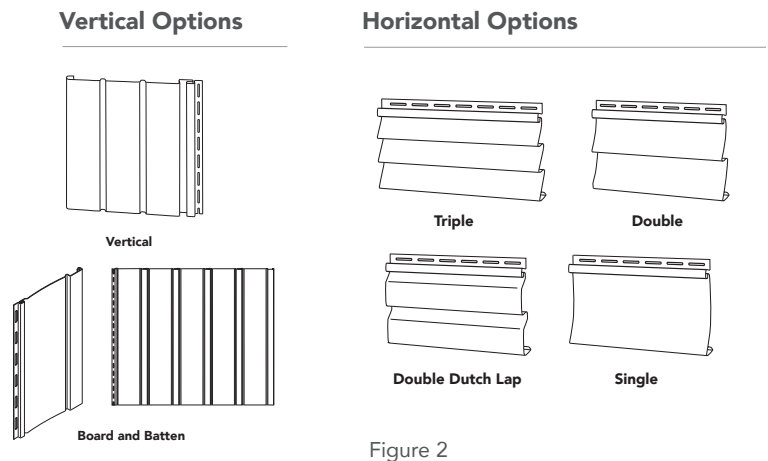

Figure 2

Soffit Options

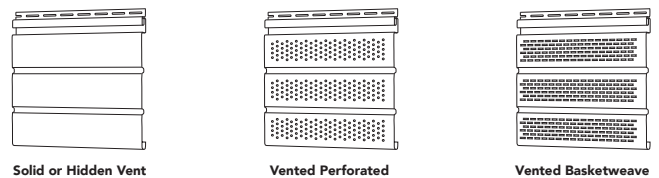

Figure 3

BASIC INSTALLATION TOOLS AND EQUIPMENT

Power Saw

A bench or radial-arm power saw can speed the cutting of the siding or soffit. A fine-tooth plywood blade should be used with the blade installed in the reverse direction. Some applicators prefer a handheld power saw. In extremely cold weather, move the saw through the material slowly to prevent chipping or cracking (Figures 4 & 5).

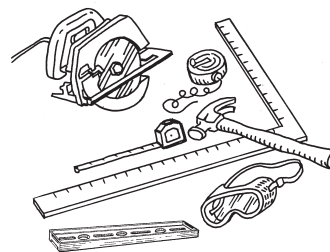

Figure 4

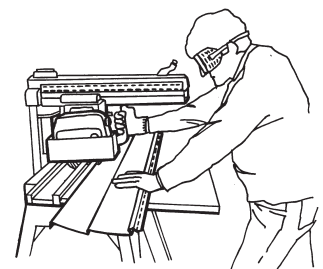

Figure 5

Utility Knife

Vinyl is easy to cut, trim, and score with a utility knife or scoring tool (Figure 6).

Tin Snips

Good quality tin snips or compound aviation-type snips will speed the cutting and shaping of the vinyl (Figure 6).

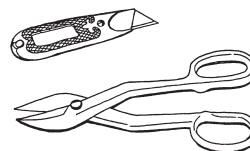

Figure 6

NOTE: A saw blade set up in reverse direction should be used only for cutting vinyl. Do not attempt to use it on other materials such as wood, plywood, etc.

MATERIALS, TOOLS, AND ACCESSORIES

SPECIALTY TOOLS

Field Forming Brake

This tool can be used to field form aluminum trim sheet (Figure 7).

Nail Hole Slot Punch

Occasionally, it may be necessary to elongate a nail hole slot to hit a stud. The hole is elongated to allow for expansion and contraction (Figure 7).

Snap Lock Punch

A snap lock punch is used to punch lugs in the cut edges of siding to be used for the top or finishing course at the top of a wall, or underneath a window (Figure 7).

Zip Lock (Unlocking) Tool

Remove or replace a siding panel with the zip lock tool. Insert the curved end of the tool under the end of the panel and hook onto the back lip of the buttlock. To disengage the lock, pull down and slide the tool along the length of the panel. Use the same procedure to relock a panel (Figure 7).

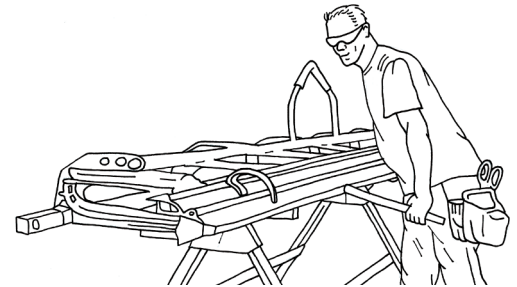

Field Forming Brake

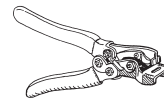

Nail hole slot punch

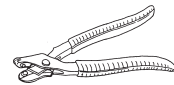

Snap lock punch

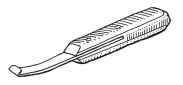

Zip lock (unlocking) tool

Figure 7

ACCESSORIES

Outside and Inside Corner Posts

Corner posts are used to provide a finished edge at an inside or outside corner. The siding from adjoining walls fits neatly into the inside or outside corner post channels. Appropriate widths of channel openings are available to accommodate various configurations of siding.

Trim and Molding

A complete line of accessories is used to give every installation a professional appearance, while providing a water-resistive facade. Some accessories include trim, starter strips, J-channels, F-channels, drip caps, utility trim, and double utility trim (Figure 8). Each of these accessories will be addressed in more detail throughout this manual.

Please reference the Design Guide on www.vinylsiding.org for further information and/or additional options regarding Architectural Design Options.

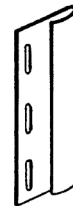

Utility trim

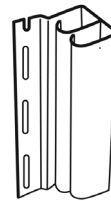

Double utility trim

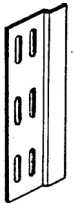

Starter strip

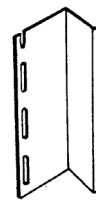

Drip cap/flushing

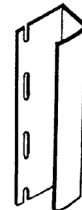

J-channel

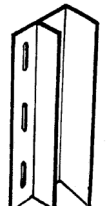

F-channel

Figure 8

GETTING STARTED

WALL SUBSTRATE MATERIALS

Sheathing

Vinyl siding should be applied over a sheathing that provides a smooth, flat surface. Consult local building codes for sheathing requirements. Vinyl siding must never be applied directly to studs without sheathing. As an alternative, installation of specific types of drop-in contoured foam underlayments for various styles of vinyl siding are available.

Sheathing Nailability

Vinyl siding can be installed over common wood sheathings such as plywood, oriented strand board (OSB), or other materials (e.g., foam plastic insulating sheathing). For specific information on use of various types of sheathing refer to the most current version of the IRC.

Water-Resistive Barrier

Vinyl siding should be installed over a continuous water-resistive barrier to stop the intrusion of incidental water. Refer to page 3 for more information on water-resistive barriers. Check your local building code for requirements in your geographic area.

Flashing

Code-compliant flashing should be integrated with the water-resistive barrier and applied around windows, doors, corners, other openings and roof lines.

GETTING STARTED

HOW TO MEASURE

Estimating Required Materials

- Make houses can be broken down into shapes of rectangles or triangles, or a combination of both.
- The area to be sided can be determined by measuring the height and width of the house, including windows (Figure 9).
- Total all of the measurements for the areas to be sided. Windows and doors are not usually deducted. Including them will provide an allowance factor for waste. If the windows and doors are extremely large (such as a garage or sliding glass doors), some deductions can be made (Figures 10–12).
- To estimate the amount of starter strip required, measure the linear feet around the entire base of the house.
- Add siding to all material estimates to allow for waste, depending on the pitch of the roof and other house-specific factors.
- To estimate the total pounds of fasteners required, multiply the total square feet of siding by 0.005 for aluminum nails and 0.01 for roofing nails, staples, and screws.
- Every 100 square feet (9.29 square meters) is called a “square” for ordering purposes.

Height ___ feet (meters) × width ___ feet (meters) =
___ square feet (square meters)

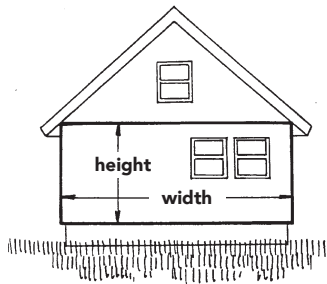

Figure 9. Wall areas

$\frac{1}{2}$ height × width =
___ area of gable (square feet/meters)

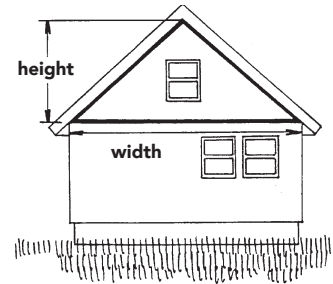

Figure 10. Gable areas

$\frac{1}{2} (A + B) \times C + \frac{1}{2} B \times D =$
___ total area of gable (square feet/meters)

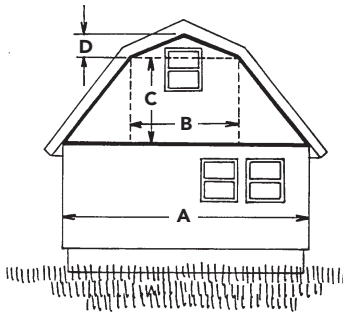

Figure 11. Gambrel roof house

$\frac{1}{2}$ height × width =
___ area of dormer (square feet/meters)

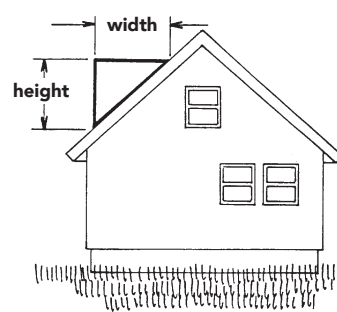

Figure 12. Dormer areas

NOTE: The amount of siding needed/waste generated for a vertical siding job will be determined by the height of the wall versus the length of the panels.

FASTENER CHOICES

Use aluminum, galvanized steel, or other corrosion-resistant nails, staples, or screws when installing vinyl siding. Aluminum trim pieces require aluminum or stainless steel fasteners.

Fastening Procedures

- Minimum fastener length must be sufficient to penetrate sheathing or nailable substrate and framing a total of a minimum of 1 1/4" (32mm) or in accordance with the manufacturer's installation instructions.
- Review the siding manufacturer's instructions and your local building codes for variations that may apply to specific siding or geographic areas.

NAILS

Nail heads should be 5/16" (7.9mm) minimum in diameter. Shank should be 1/8" (3.2mm) in diameter (Figure 13).

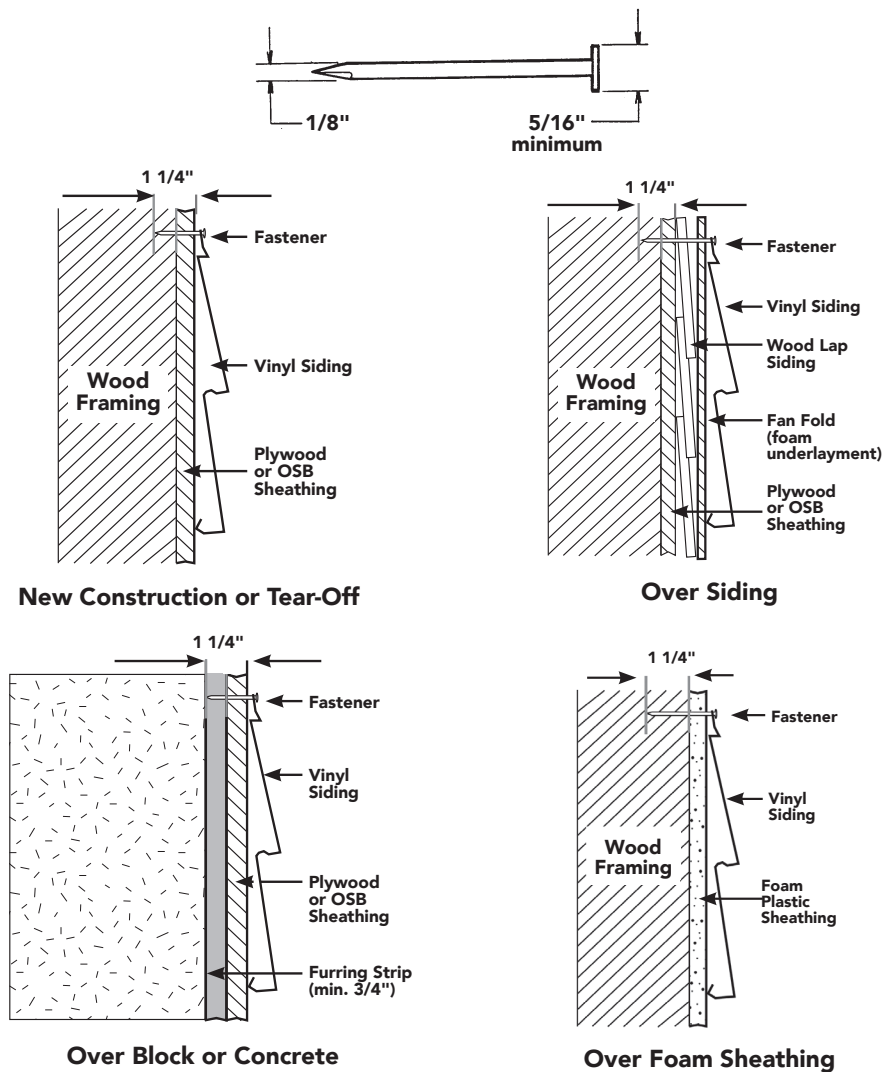
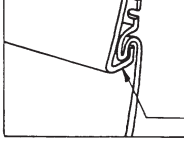

Figure 13

FASTENING PROCEDURE

Vinyl siding can expand and contract 1/2" (12.7mm) or more over a 12' 6" (3.81m) length during normal, year-round changes in temperature. **Whether using a nail, screw, or staple to fasten the siding, the following basic rules must be followed:**

- Make sure the panels are fully locked along the length of the bottom, but do not force them up tight when fastening. 
- Do not drive the head of the fastener tightly against the siding nail hem. Allow approximately 1/32" (0.8mm) clearance (the thickness of a dime) between the fastener head and the vinyl. **Tight nailing, screwing, or stapling will cause the vinyl siding to buckle with changes in temperature (Figure 14).**
- When fastening, start in the center of the panel and work toward the ends.
- Center the fasteners in the slots to permit expansion and contraction of the siding (Figure 15).
- Drive fasteners straight and level to prevent distortion and buckling of the panel (Figure 16).
- Space the fasteners a maximum of 16" (406mm) apart for horizontal siding panels, every 12" (305mm) for vertical siding panels, and every 8" to 12" (203mm to 305mm) for accessories. These distances may be increased if the manufacturer permits greater spacing based on wind load testing. Start fastening vertical siding and corner posts in the top of the uppermost slots to hold them in position (Figure 17). Place all other fasteners in the center of the slots.
- If a nail slot does not allow centering/securing into a nailable surface, use a nail hole slot punch to extend the slot and allow centering of the fastener.

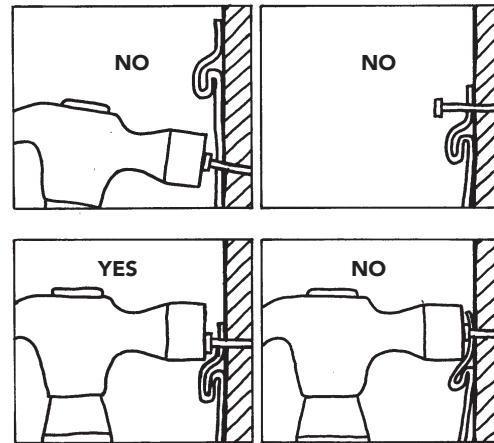

Figure 14

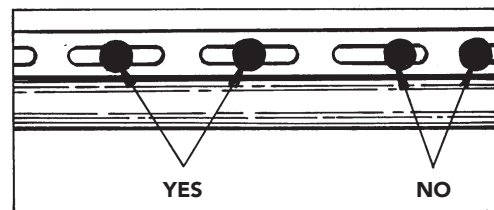

Figure 15

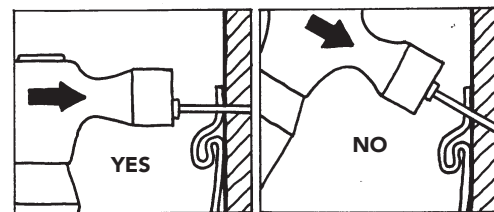

Figure 16

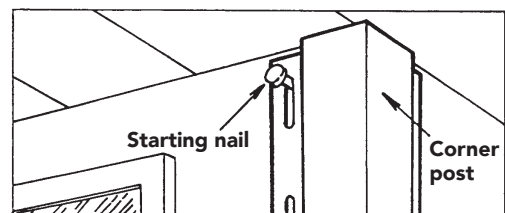

Figure 17

FASTENING PROCEDURE

Screw Fasteners

Screw fasteners can be used if the screws do not restrict the normal expansion and contraction movement of the vinyl siding panel on the wall. Screws must be centered in the slot with approximately 1/32" (0.8mm) space between the screw head and the vinyl. **Screws must be able to penetrate no less than 1 1/4" (32mm) into framing or furring and should be:**

- Size #8, truss head or pan head
- With steel studs, the use of self-tapping sheet metal screws must be used.

Staples

If staples are being used instead of nails or screws, consult your local building codes. The manufacturer may permit the use of staples as an alternative to nails. Be sure to observe any limitations with respect to the wind load design pressure rating when the siding is installed with staples. The staples must (Figure 18):

- Not be less than 16-gauge semi-flattened to an elliptical cross-section.
- For staple length refer to Figure 13 diagrams.
- Be wide enough in the crown to allow free movement of the siding (approximately 1/32" [0.8mm] away from the nailing hem).

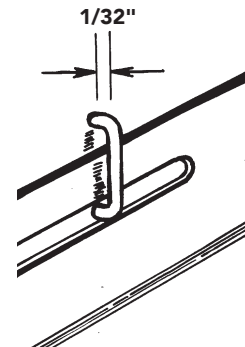

Figure 18

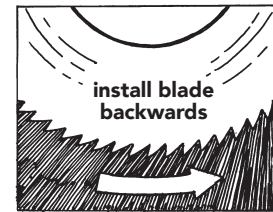
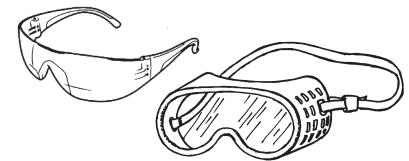

Figure 19

CUTTING SIDING

When cutting vinyl siding or soffit, follow these guidelines:

- The use of protective eyewear is always recommended for all cutting and nailing operations. As on any construction job, use proper safety equipment and follow safe construction practices.
- With a circular saw, always install the fine-tooth (plywood) blade backwards on the saw for a smoother, cleaner cut, especially in cold weather (Figure 19). Cut slowly. Do not attempt to cut materials other than vinyl with a reversed direction saw blade.

Caution! Use of a backwards blade on any other materials could be unsafe.

- With tin snips, avoid closing the blades completely at the end of a stroke for a neater, cleaner cut (Figure 20).
- With a utility knife or scoring tool, score the vinyl face up with medium pressure and snap it in half. It is not necessary to cut all the way through the vinyl (Figure 21).

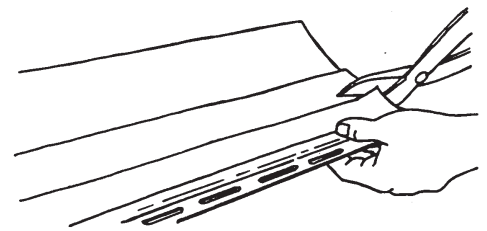

Figure 20

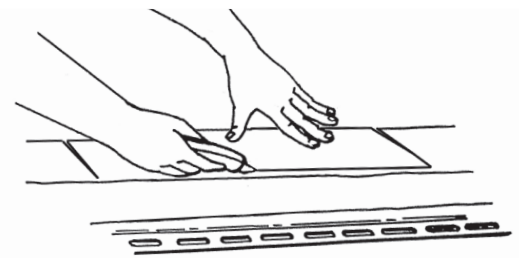

Figure 21

PREPARING THE WALLS

A flat, level wall surface is necessary for proper installation of vinyl siding. Install flashing before starting to apply the siding.

Unless already installed, a water-resistive barrier should be applied to the house prior to installing vinyl siding. Refer to page 3 for more information on water-resistive barriers. Consult your local building code for requirements in your geographic area.

(See Fastening Procedure and Figure 15.)

New Construction

- **TIP:** To reduce the possibility of floor-plate compression, drywall, roofing, or other heavy building materials should be installed or stored throughout the house prior to the installation of vinyl siding. Floor-plate compression can result in buckled siding at the intersection of the floor and the wall.

Re-siding

- Nail down loose boards of existing siding and replace any rotten ones (Figure 22). Do not install vinyl siding over rotting wood.
- Scrape off loose caulk and re-caulk around windows, doors, and other areas to protect from moisture penetration.
- Remove all protrusions such as gutters, downspouts, and light fixtures.
- Check all walls for evenness and install furring strips where necessary. When installing furring strips, please take appropriate measures to establish a smooth and continuous surface. (Figure 23).

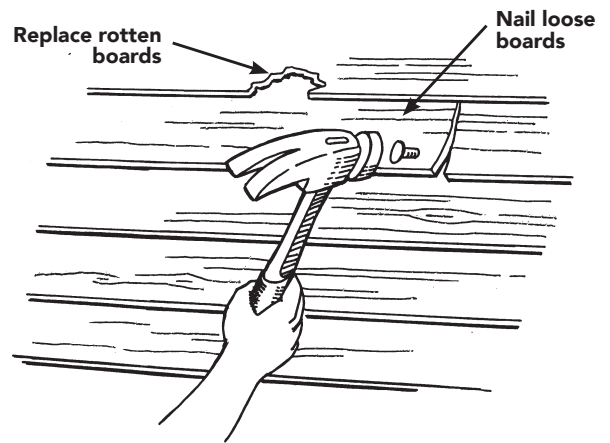

Figure 22

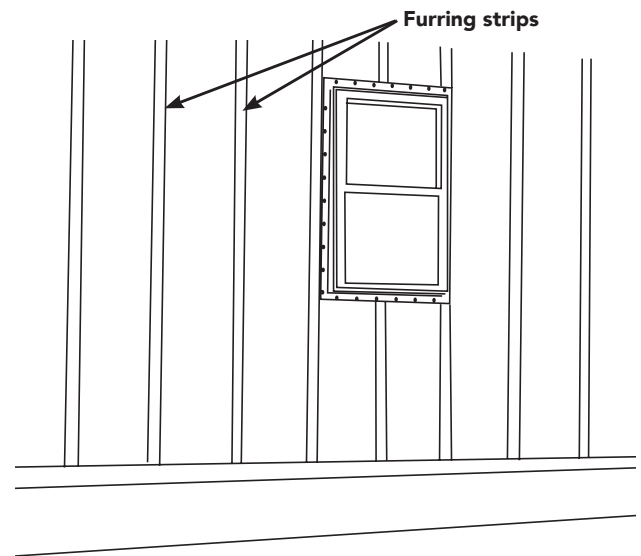

Figure 23

NOTE: In cases where the lower portion of a horizontal siding panel must be trimmed so that it may be installed over steps, porches, etc., the panel should be built out ("furred") for proper angle and rigidity. Utility trim can be used to seal the cut edge of the panel and then secured to the wall.

INSTALLING ACCESSORIES

Before the siding itself can be hung, a number of accessories must be installed first, including starter strips, corner posts, window flashing, trim, and J-channels over the roof lines and around openings.

Outside and Inside Corner Posts

- A water-resistive material should be used to flash the inside and outside corners a minimum of 10" (254mm) on each side before installation of the corner posts.
- Inside corner posts can be a single or double J-channel, or a factory-formed inside corner.
- Place the corner post in position, allowing a 1/4" (6.4mm) gap between the top of the post and the eave or soffit. Position a nail at the top of the upper slot on both sides of the corner post, leaving a gap of approximately 1/32" (0.8mm) between the nail heads and the corner posts. The corner post hangs from these nails. The balance of the nailing should be in the center of the slot, 8" to 12" (203mm to 305mm) apart, again leaving 1/32" (0.8mm) between the nail head and the corner post. This allows for the expansion and contraction to occur at the bottom. The corner post should extend 3/4" (19mm) below the starter strip. Make sure the posts are plumb (i.e., vertically straight) and square to the wall (Figures 24 and 25). Cut away any exposed nail hems.
- If more than one length of corner post is required, overlap the upper piece over the lower piece by cutting away 1" (25.4mm) of the nailing flange on the top piece. Overlap 3/4" (19mm), allowing 1/4" (6.4mm) for expansion. This method will produce a visible joint between the two posts, but will allow water to flow over the joint, reducing the chance of water infiltration.

Capping a Corner Post

- Corner posts on homes with a second-story overhang need to be capped by making the cuts shown (Figure 26). Fold the flaps created over each other as indicated.
- Drill a 1/8" (3.2mm) hole in the center, through both layers of vinyl, and install a pop rivet to hold them in place. Cut a notch in both layers to allow clearance for the corner.

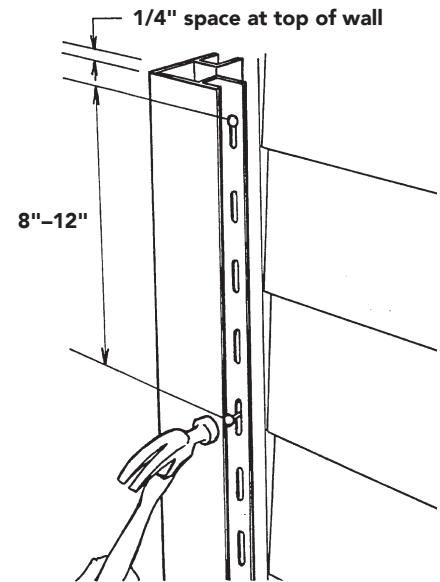

Figure 24

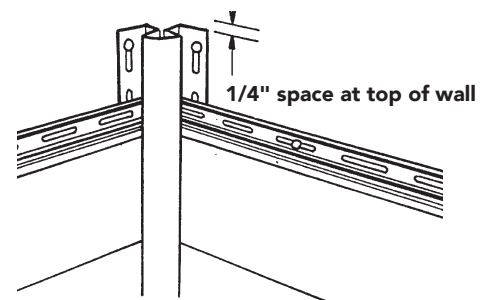

Figure 25

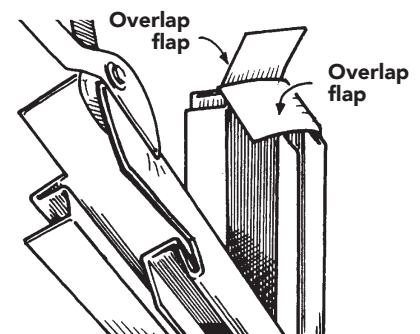

Figure 26

INSTALLING ACCESSORIES

STARTER STRIP

In order for the siding to be installed properly in a level fashion, the starter strip at the bottom of the wall must be level.

- Determine the lowest point of the wall that will be sided; from that point, measure up 1/4" (6.4mm) less than the width of the starter strip and partially drive a nail at one corner.
- Attach a chalkline; go to the next corner and pull the line taut.
- Make sure the line is level by using a line level or a 4' (1.2m) level.
- Snap the chalkline and repeat the procedure around the entire house.
- Optional method to determining the position of the starter strip in new construction and some re-siding applications: Measure down from the soffit at one corner of the house to the top of the foundation and subtract 1/4" (6.4mm) less than the width of the starter strip. Make a mark on the wall and record the measurement. Transfer the measurement to the other corner of the wall. Snap a chalk line in between the corners at the marks. Repeat the procedure around the entire house.
- Using the chalkline as a guide, install the top edge of the starter strip along the chalkline, nailing at 8" to 12" (203.2mm to 304.8mm) intervals. Allow space for the corner posts, J-channels, etc.
- Keep the ends of starter strips approximately 1/4" (6.4mm) apart to allow for expansion (Figure 27).
- Nail in the center of the starter strip nailing slots.
- For insulated vinyl siding, the starter strip needs to be spaced away from the wall to accommodate the thickness of the backing on the siding. Consult the manufacturer's instructions for specific materials or techniques.

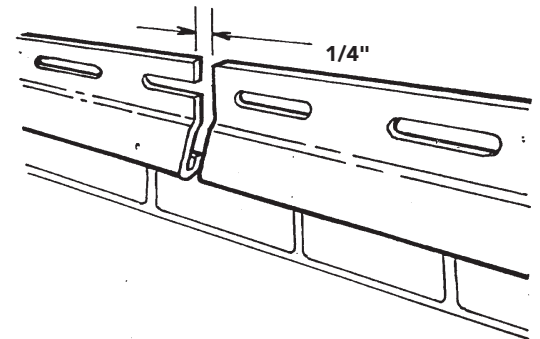

Figure 27

NOTE: When insulation or sheathing is used, fur the starter strip, if necessary, to accommodate the thickness of the siding. For vertical siding starter methods, see the section on vertical siding.

INSTALLING ACCESSORIES

WINDOWS, DOORS, AND ROOF LINES

Flashing New Window Installations

If installing both a new window and flashing, refer to window manufacturer's instructions and ASTM E2112, Standard Practice for Installation of Exterior Windows, Doors and Skylights for the proper flashing installation method for the window type and wall configuration on the project.

Flashing Previously Installed Nail Fin Windows

If a nail fin (in new construction) window has been previously installed without flashing, the following instructions should be followed:

- Apply a continuous bead of sealant to the nailing flange of the sill in a manner that covers the nails and nail slots. Apply a minimum of 9" (229mm) wide horizontal sill flashing level with the bottom edge of the existing window by pressing the flashing into the sealant bead at its top edge. Cut the sill flashing long enough to extend a minimum of 9" (229mm) beyond each jamb. Fasten the sill flashing at the bottom and side edges (Figure 28).
- Apply a continuous bead of sealant to the nailing flange of the jambs in a manner that covers the nails and nail slots. Continue the bead of sealant at the jambs vertically a minimum of 8 1/2" (216mm) above the head of the window to allow for bedding the top portion of the jamb flashing into sealant in the next step. Install the jamb flashing by pressing the flashing into the sealant beads at the window jambs. Extend the bottom edge of the jamb flashing approximately 1/2" (12.7mm) short of the sill flashing edge and extend the top edge approximately 8 1/2" (216mm) beyond the head of the window, where the head flashing will be placed next. Fasten the jamb flashing along the edges further most from the window (Figure 29).

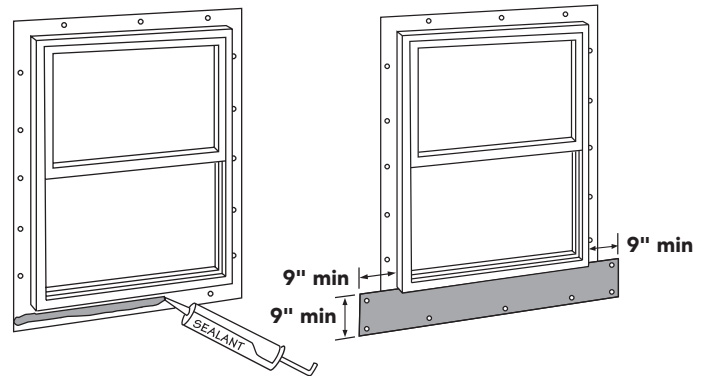

Figure 28

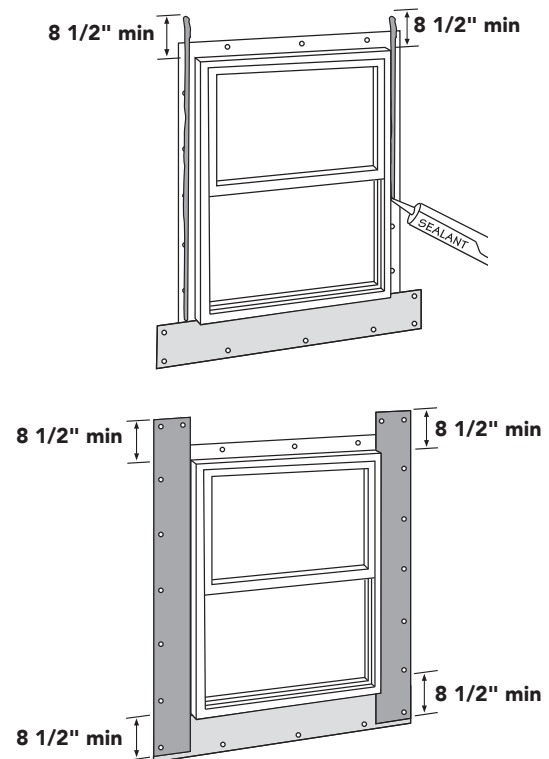

Figure 29

NOTE: Sealant should be compatible with window, flashing, and water-resistive barrier materials. Contact sealant manufacturer for job-specific recommendations. The use of self-adhering flashing is acceptable.

INSTALLING ACCESSORIES

- Apply a continuous bead of sealant to the nailing flange of the head in a manner that covers the nails and nail slots. Add an additional bead of sealant horizontally, in line with the top of the head flashing. Install the head flashing by pressing the bottom edge of the flashing into the sealant bead previously applied across the mounting flange. Extend the ends of the head flashing approximately 1" (25.4mm) beyond the jamb flashing at each end. Fasten the head flashing into place along the top edge (Figure 30).

Flashing Previously Installed Window with Exterior Casing (Brick Mold)

If a window with exterior casing (e.g., brick mold) has been previously installed without flashing, the following instructions should be followed:

- Ensure that exterior casing is sealed to the exterior sheathing or water-resistive barrier with a good quality sealant.
- Exterior casing may be covered with aluminum or vinyl trim sheet. This can be accomplished by using a portable field brake and bending instructions from the brake manufacturer. The trim sheet should be installed in weatherboard fashion. The bottom piece should be installed first, and each piece should overlap the piece below wherever they join.
- Install rigid head flashing (i.e., drip cap) on top of the top piece of exterior casing, covering trim sheet installed in the previous step. The ends of the rigid head flashing must extend to the outer edges of the exposed legs of the side J-channels. Cut a notch on the ends of the rigid head flashing and bend them down over the sides of the exterior casing. The rigid head flashing must be sealed to the exterior sheathing and to the top of the exterior casing (Figure 31).

Trim

J-channel is used around windows and doors to receive the siding.

Follow the steps below when applying trim.

- Cut and bend the tab of the top piece of J-channel down to provide flashing over the side J-channel.
- Fold the bottom end of the side piece of J-channel inward at the bottom of the window, to fit over the existing J-channel to prevent water from entering under the sill.
- Cut the side J-channel members longer than the height of the window or door and notch the channel at the top.
- Miter cut the free flange at a 45° angle and bend the tab down to provide flashing over the side members (Figure 31). A similar miter and tab may be provided at the bottom of the window, depending on the sill's condition. The J-channel should fit snug to the window.

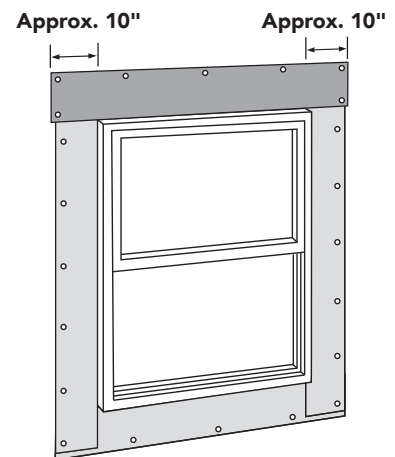
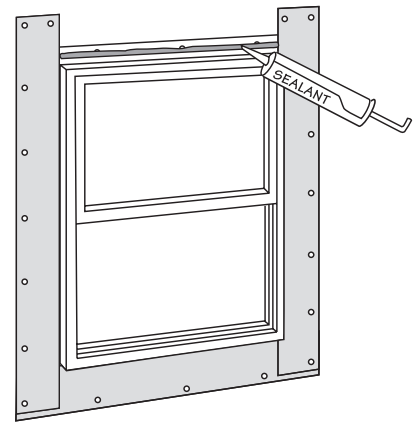

Figure 30

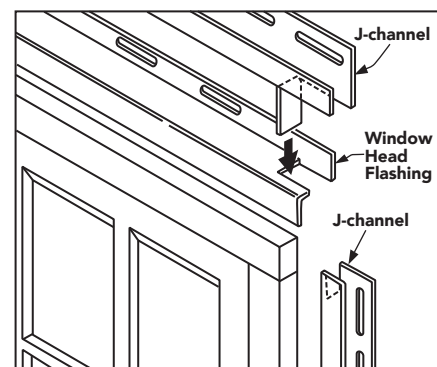

Figure 31

INSTALLING ACCESSORIES

J-CHANNEL OVER ROOF LINES

Ensure the step flashing is installed before the J-channel to prevent water infiltration along the intersection of a roof and wall.

- Keep the J-channel a minimum of 1/2" (12.7mm) from the roofing material due to possible heat transfer to the vinyl J-channel causing distortion. Chalk a straight line up the roof flashing to guide J-channel installation.

Tip: You can use another J-channel laid over the shingles as a spacer to create the straight line desired.

- Overlap the J-channel (lapping the upper piece over the lower piece) if it is necessary to use more than one piece. (Figure 34)
- Extend the J-channel past the edge of the roof in order to ensure proper runoff. A diverter can be used; see Figures 42 and 43.
- With dark shingles, or a south or west exposure, it is recommended to either use a metal J-channel or to install the vinyl J-channel as far away from the roofing as is aesthetically acceptable, having first ensured that there is sufficient flashing behind the J-channel to prevent water infiltration.
- Fasten the nail, screw, or staple that is closest to the roof line at the far end of the nail hem slot, to ensure that siding will expand away from the J-channel (Figure 32).

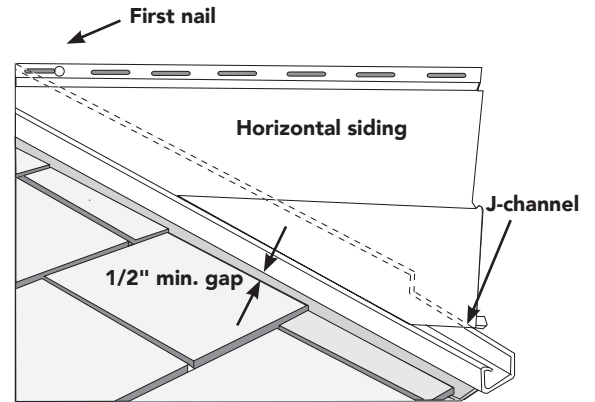

Figure 32

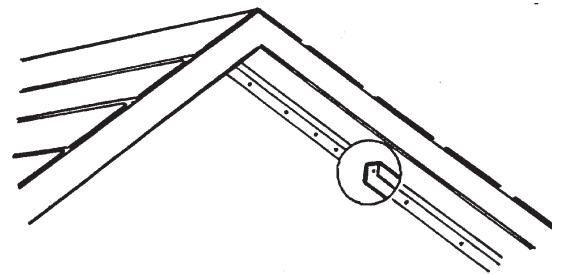

Figure 33

GABLE AND TRIM

Before applying siding to the gables, the J-channel should be installed to receive the siding at the gable ends (Figure 33):

- Where the left and right sections meet at the gable peak, let one of the sections butt into the peak with the other section overlapping.
- A miter cut should be made on the face flange of this piece for better appearance.
- Fasten the J-channel every 8" to 12" (203mm to 305mm).
- If more than one length of J-channel is required to span a wall surface, be sure to overlap the channels by 3/4" (19mm). (Figure 34).

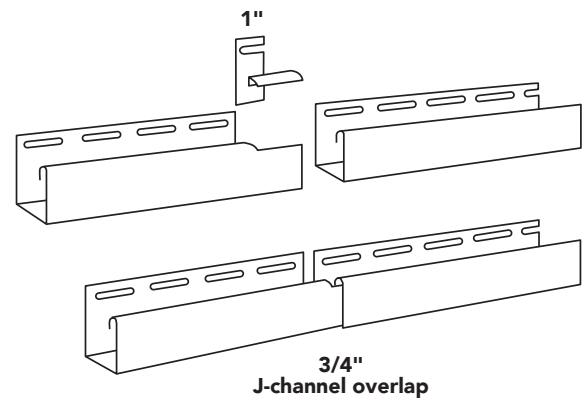

Figure 34

HORIZONTAL SIDING INSTALLATION

INSTALLING PANELS

- The first course (row of panels) should be placed in the starter strip and securely locked along the entire length of the siding panel. Make sure the panel is securely locked before fastening.
- Fasten the panels in the center of the nailing slots beginning in the center of the panel and working toward the ends (see pages 12 and 13 for specific information on fastening and fasteners). Be sure that nail length is sufficient to penetrate framing or framing plus nailable sheathing.
- Allowance should be made for expansion and contraction by leaving a 1/4" (6.4mm) gap between the siding and all corner posts and channels. Increase to 3/8" (9.5mm) when installing in temperatures below 40° F (4.4° C). If the panels are 20 feet (6.1 meters) or longer, refer to the manufacturer's instructions for how to increase the gap.
- Do not drive the head of the fastener tightly against the nail slot. Leave approximately 1/32" (0.8mm) between the fastener head and the vinyl siding (about the thickness of a dime).
- Do not force the panels up or down when fastening. Panel locks should be fully engaged; however, the panels should not be under vertical tension or compression when they are fastened.
- Since vinyl siding moves as the temperature changes, make certain that the panels can move freely in a side-to-side direction once fastened.
- Check every fifth or sixth course for horizontal alignment (Figure 35). Also check siding alignment with adjoining walls.
- When panels overlap, make sure they overlap by approximately 1" (25.4mm) (Figure 36).
- When overlapping insulated vinyl siding, no gap is needed between the foam at the ends of the panels. Be sure to butt each piece of foam together (Figure 37), unless installing in cold weather (always consult the manufacturer's instructions).
- Stagger the siding end laps so that no two courses (rows of panels) are aligned vertically, unless separated by at least three courses.
- Always overlap joints away from entrances and/or away from the point of greatest traffic. This will improve the overall appearance of the installation (Figure 36).
- Avoid beginning and ending siding courses with panels shorter than 24" (610mm).

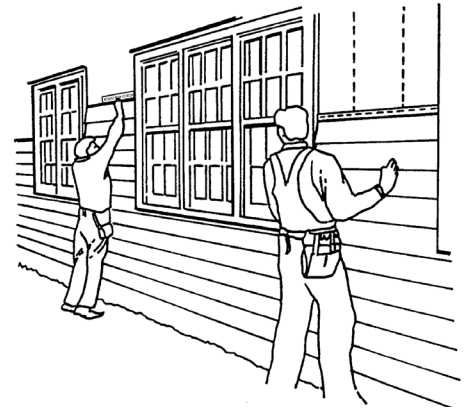

Figure 35

Overlap away from areas of high traffic (e.g., doors)

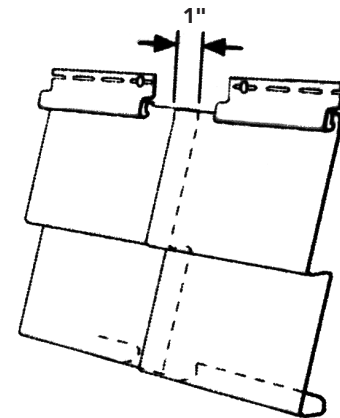

Figure 36

Foam backer touching

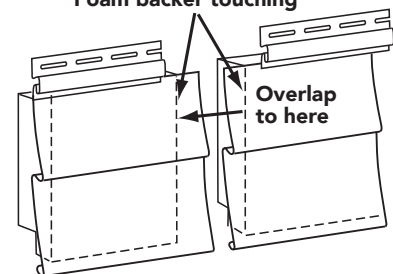

Figure 37

HORIZONTAL SIDING INSTALLATION

FITTING SIDING AROUND FIXTURES

Use a commercially available split or hinged trim ring (Figure 38) to fit siding to a penetration such as a faucet or railing attachment, following the manufacturer's installation instructions. If a commercial trim ring is not available for the application, refer to Figure 39, which illustrates how to fit the siding to the penetration.

In addition, the following tips are suggested:

- Install siding so that you have the factory end laps intersect at the fixture.
- Cut an opening 1/4" (6.4mm) bigger than the fixture or the trim ring.
- When cutting, match the shape and contour of the obstruction.
- In a situation when a removeable light fixture occurs, use a 2-piece mounting block.
- For insulated vinyl siding, due to the thickness of the insulation, it may be necessary to shim out the fixture or window and door trim to achieve the desired appearance.

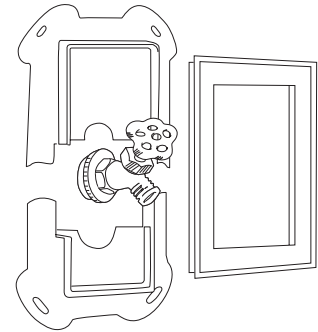

Figure 38

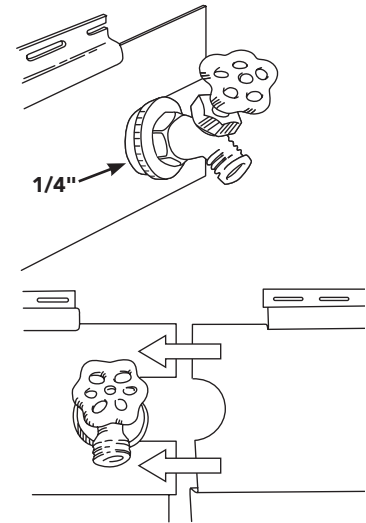

Figure 39

FITTING UNDER WINDOWS

To mark the section to be cut, perform the following:

- Hold the panel under the window and mark the width of the window opening on the panel. Add approximately 1/4" (6.4mm) to both sides to allow for expansion and contraction of the siding. These marks represent the vertical cuts (Figure 40).
- Lock a small piece of scrap siding into the lower panel next to the window. This will be used as a template for the horizontal cuts. Mark it 1/4" (6.4mm) below the sill height.
- Transfer the horizontal measurement to the panel, which will be installed under the window. Measurement may not be the same on both sides of the window.
- Cut the panel with tin snips and a utility knife.

The cut panel is now ready for installation under the window. Perform the following:

- Using a snap lock punch, punch the vinyl siding along the cut edge every 6" (152mm) so the raised lug is on the outside face.
- Install utility trim (or double utility trim) under the window, as a receiver for the cut siding. Utility trim is used any time the top lock has been removed from the siding. Furring may be needed to maintain the face of the panel at the desired angle.
- Install the siding panel, making sure the lugs (from the snap lock punch) lock into the utility trim (Figure 41).

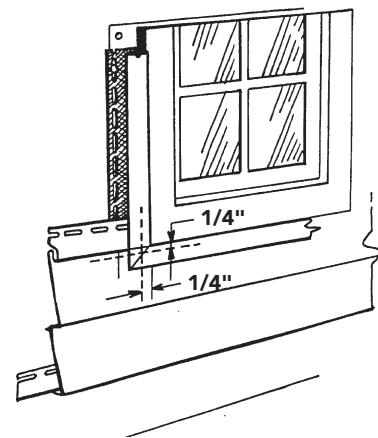

Figure 40

HORIZONTAL SIDING INSTALLATION

SIDEWALL FLASHING AT ROOF LINES

- Run the siding until the last full course under the roof area.
- Cut a diverter from aluminum trim sheet, making sure it sits on the nail hem of the last full course (Figure 42). Make sure the diverter is placed inside the receiving pocket of the vertical J-channel and is tucked behind the nail hem of the J-channel following the roofline for best drainage.
- If a water-resistive barrier is present, a cut should be made in that barrier to allow the diverter to slip behind the roof step flashing and the J-channels. That cut will need to be sealed with tape, approved by the housewrap (WRB) manufacturer once the diverter is installed.
- As an alternative to the diverter, create a “kickout” from metal flashing, as shown in Figure 43.

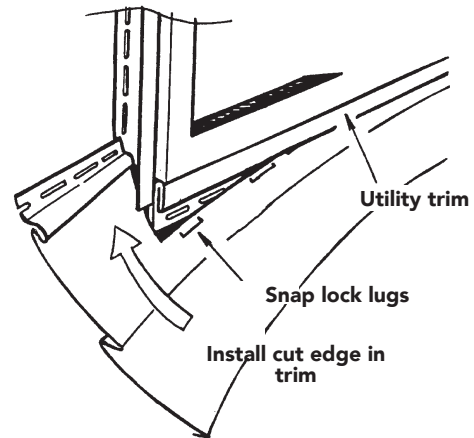

Figure 41

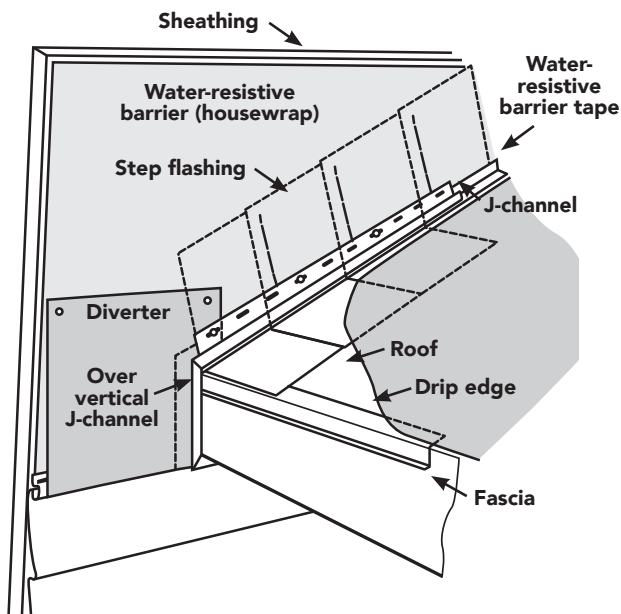

Figure 42

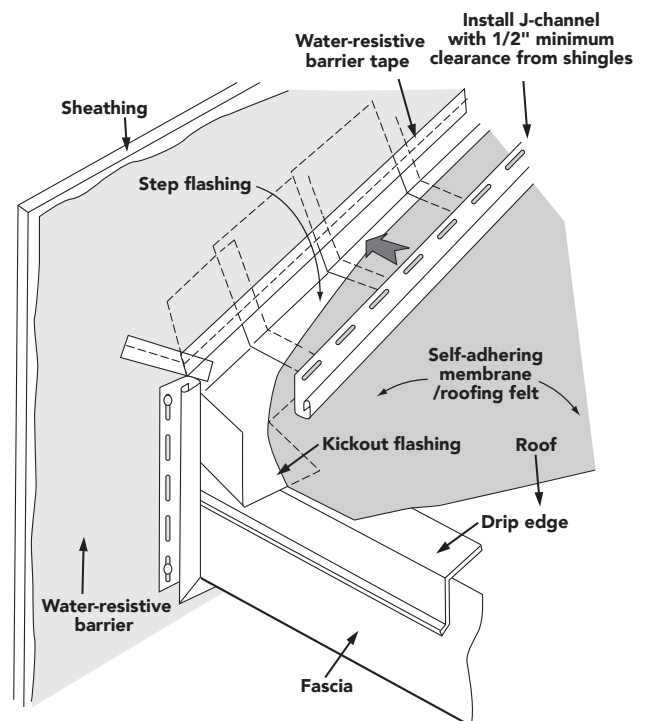

Figure 43

NOTE: “Kickout flashing” (Figure 43) is an additional flashing strip that extends beyond the edge of the fascia that is required in some cold-climate localities.

HORIZONTAL SIDING INSTALLATION

FINISHING AT THE TOP OF WALLS

Before the final course of siding is installed on the wall, any soffit accessories that will be used on the eaves must be installed. See the Soffit Installation section.

Gable Ends

To install around gable ends, make a pattern that duplicates the slope of the gable (Figure 44):

- Lock a short piece of siding into the gable starter course (i.e., the last course before the gable starts).
- Hold a second piece of siding against the J-channel at the slope of the gable. Mark the slope with a pencil on the short piece of siding.
- Remove the short piece and cut along the pencil line as a pattern for the gable angle cuts. Repeat the procedure on the opposite side of the gable. Check the angle template every few courses.
- It is necessary to fasten the last panel at the gable peak with a trim nail. This is one of the few times a nail should be placed in the face of the vinyl siding (Figure 45). Minimum fastener length must be sufficient to penetrate sheathing other nailable substrate and framing a total of a minimum of 1 1/4" (32mm) or in accordance with the manufacturer's installation instructions.

Eaves Treatment

The last course of siding may be cut to fit the eaves opening (Figure 46).

- Measure from the soffit to the base of the upper lock on the previous course. Subtract 1/4" (6.4mm). Mark this dimension on the panel to be cut, measuring from the bottom edge of the panel. It is a good idea to check the dimension in several locations along the length of the wall.
- Using a snap lock punch, punch the vinyl siding along the cut edge every 6" (152mm), so the raised lug is facing outward.
- Push the siding into the utility trim (or double utility trim) that has been nailed in place along the top of the wall. Furring may be needed to maintain the face of the panel at the desired angle. The raised lugs will catch and hold the siding firmly in place.

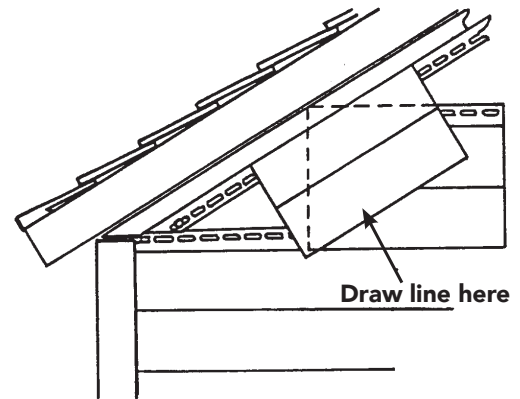

Figure 44

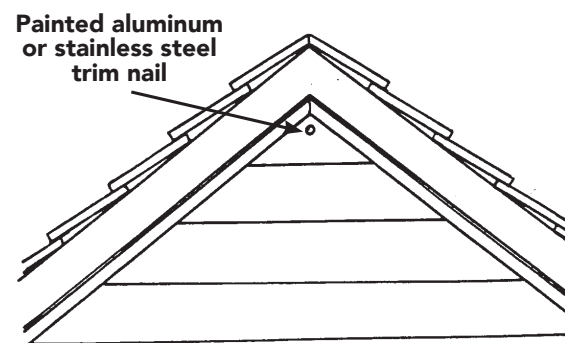

Figure 45

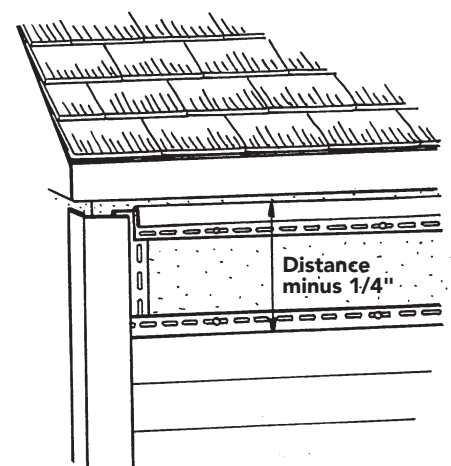
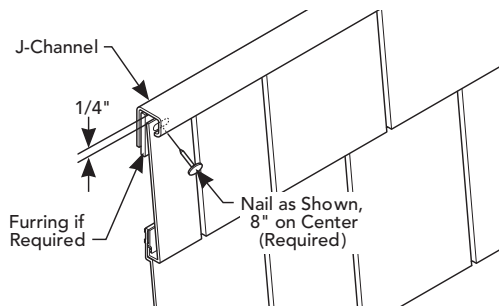

Figure 46

HORIZONTAL SIDING INSTALLATION

- Failure to use proper connection can create a weak point for the system. (Figure 47)
- Use of utility trim and punch-locked siding is critical under windows and at the top of the walls.
- Using a snap lock punch (or other nail hole-creating tools), punch every 6" along the cut edge of vinyl siding and every 8" along the cut edge of polypropylene siding so the raised lug is on the outside face.
- Any time the top lock has been removed from siding, utility trim should be used as a receiver to secure the punched-tab siding panel.
- Furring may be required.

POLYPROPYLENE SIDING



INSULATED VINYL SIDING

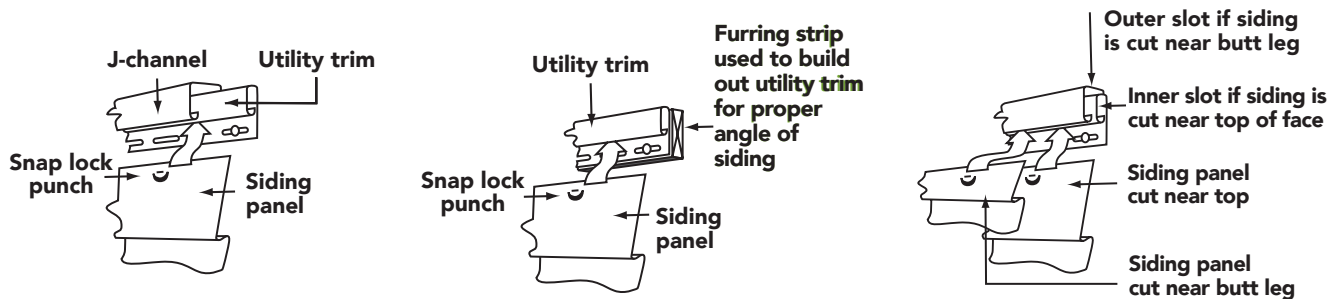
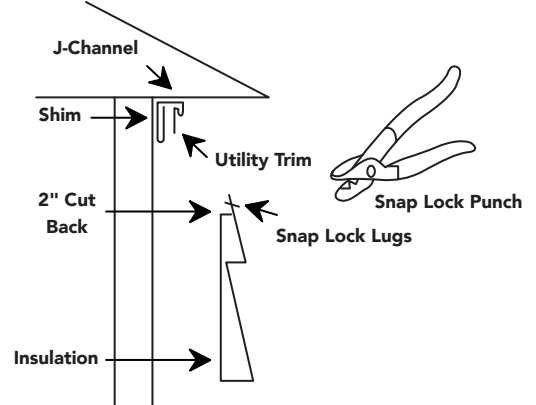

*Snap lock punches should be about 6" on center

Figure 47

HORIZONTAL SIDING INSTALLATION

OPTIONAL EAVE AND GABLE TREATMENT

Use a two-piece cover/receiver along the rake and eave (Figure 48). Install the receiver flush with the top of the wall. Punch nail slots along the top edge of the panel every 16" (406mm). Use those nail slots to attach the panel to the wall. Snap the cover into place over the nails.

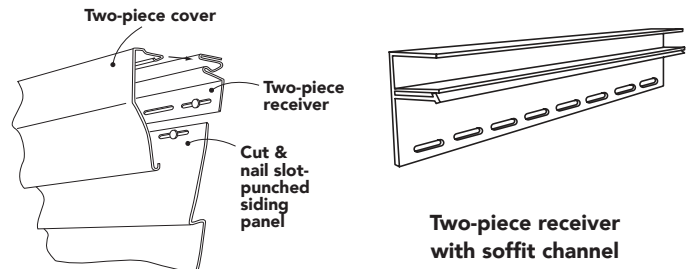

Figure 48

Transition from Horizontal to Vertical

- Finish the last course of horizontal siding with the J-channel and finish trim or double finish trim. Install head flashing and a J-channel.
- The top piece of J-channel must have minimum 3/16" (4.8mm) diameter weep holes drilled no more than 24" (610mm) apart to allow for water runoff, and the starter strip (J-channel) should not rest on head flashing because it will block weep holes. Leave a gap as shown (Figure 49).

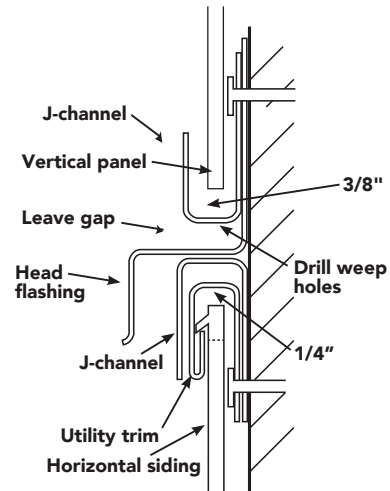

Figure 49

Transition from Brick to Vinyl Siding

- Caulk where the sheathing meets the brick sill. A head flashing (or drip cap) should be field formed and installed, then caulked where it meets the brick sill. The top of the flashing needs to be integrated or sealed to the water barrier (Figure 50).
- If horizontal siding is used, starter strip should be used, and it is necessary to provide at least 3/8" (9.5mm) clearance for proper engagement of the siding. If using J-channel, consult local building codes for variations that may apply to geographic areas and refer to the manufacturer's specific installation instructions.
- Use J-channel to receive vertical siding. Drill minimum 3/16" (4.8mm) diameter weep holes in the bottom of the J-channel no more than 24" (610mm) apart. Leave a gap between the J-channel and the flashing.

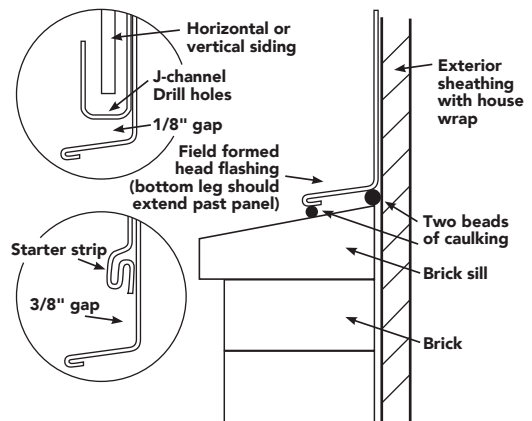

Figure 50

VERTICAL SIDING AND ACCESSORIES INSTALLATION

PREPARATION

See "Preparing the Walls" section on page 15. When installing vertical siding, however, follow these additional preparatory steps:

- Install horizontal furring strips, or a solid nailable sheathing prior to the siding, if needed, to level the surface or provide sufficient material for fastener penetration. If furring strips are used, install them 12" (305mm) on center or as specified in the siding manufacturer's installation instructions. Be sure to use furring or sheathing material with the thickness specified in the manufacturer's instructions. If the instructions specify the use of special nails (e.g., ring shank nails), be sure to use them and follow the instructions for nail spacing.
- Snap a level chalkline around the base of the sidewalls, this will represent the top of the J-Channel (starter strip). Install J-channel along the chalkline as a receiver for the vertical siding.

ACCESSORIES

As with horizontal siding, when installing vertical siding, it is necessary to install several accessories first, including corner posts and window, door, and roof trim.

Outside and Inside Corner Posts

- Leave a 1/4" (6.4mm) gap at the top of corner posts.
- Place the first nails in the uppermost end of the top nail slots to hold them in position (Figure 51). Place all other nails in the center of the slots. Nails should be 8" to 12" (203mm to 305mm) apart.
- Corner posts should extend 3/4" (19.2 mm) below the siding. Do not nail tightly; the corner post should move. When installing over a deck or a concrete surface, allow 3/8" of an inch between the bottom of the corner post and the surface.
- Use the manufacturer's approved insulated corner post to receive the additional thickness of insulation.

Bottom Receiver

- Position the top edge of a J-channel or vertical base along the previously snapped chalkline. Remember to drill minimum 3/16" (4.8mm) diameter weep holes no more than 24" (610mm) apart (Figure 52).
- Fasten every 8" to 12" (203mm to 305mm). Use the center of the nail slots. All vinyl should be fastened securely but not tightly. Sideways movement should not be restricted. Leave 1/4" (6.4mm) gaps at the corner posts (Figure 51). Where lengths adjoin, trim the nailing flange 1" (25.4mm) and overlap 3/4" (19mm) to produce a neat joint (Figure 53).

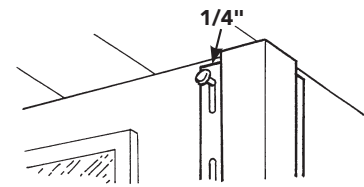

Figure 51

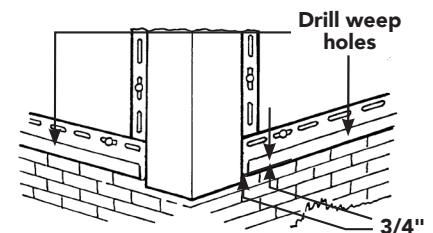

Figure 52

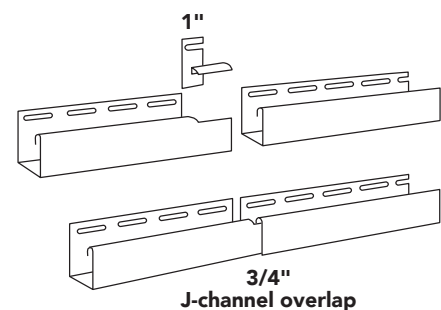

Figure 53

VERTICAL SIDING AND ACCESSORIES INSTALLATION

WINDOW, DOOR, AND ROOF TRIM

Install J-channel at the tops of the sidewalls (Figure 54). At the gable ends, snap a level chalkline along the base of the gable and install J-channel. Overlap where necessary and allow for expansion (Figure 53).

After installing flashing, trim around all windows and doors using J-channel. The following is required to divert water around the windows:

- Cut a J-channel for the bottom of the window, the width of the frame plus the width of the side J-channels and install it.
- Cut the side J-channels the length of the frame plus the width of the top and bottom J-channel. Cut notches in the top of the side J-channel. Cut and bend tabs (Figure 55) into the bottom channel. Install the side channels.
- Cut the top J-channel the width of the frame plus the width of the side J-channels. Notch the top J-channel on each end, bend the tabs into the side J-channel, and fasten the top J-channel (Figure 55).
- A miter cut and tab can be provided at the bottom of the window (Figure 56), depending on the sill's condition.

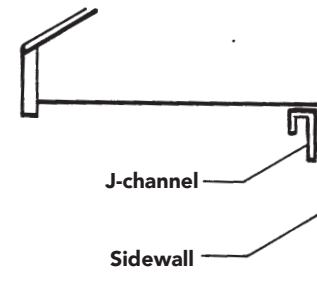

Figure 54

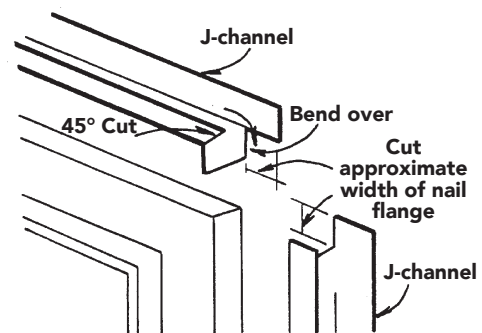

Figure 55

SIDEWALLS

- To create a balanced appearance (Figure 57), divide the length of the wall by the exposure of the vertical panel to be used. For example, if the wall requires 20 full panels plus an additional 8" (203mm), then the first and last pieces installed would be cut to a new width of 4" (102mm). Make sure to allow for proper depth in the receiving channels of the accessories at both ends when measuring.
- To install the siding, if partial panels are required, mark the line to cut by measuring from the edge of the lock of the panel and cut the panel to the proper width. This will leave a panel with an intact nail hem and proper exposure.

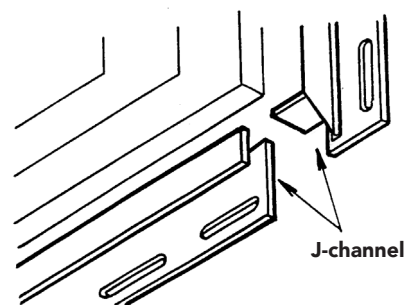

Figure 56

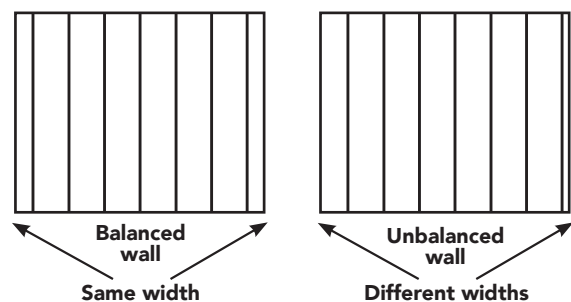

Figure 57

VERTICAL SIDING AND ACCESSORIES INSTALLATION

To start or end panels that have been cut, and at all window jambs:

- If cut is on a flat area, use a snap lock punch, and install into utility trim.
- The utility trim will need to be shimmed to maintain the face of the panel (Figure 58).
- Shims should not be needed in most cases with board-and-batten panel.
- To complete this starting piece, snap the tabs into the utility trim, plumb the panel level, and begin securing by placing a fastener at the top of the topmost full nail slot, allowing for 1/4" (6.4mm) upward movement and 3/8" (9.5mm) downward. (Some manufacturers' vertical siding instructions are different; consult with the manufacturer for specific installation instructions). Continue securing with fasteners centered in the nail slots not more than 12" (305mm) apart.
- Install successive panels by securing from the topmost full nail slot downward, as described above, then 12" (305mm) on center for the rest of the panel. Around windows, doors, and fixtures, allow 1/4" (6.4mm) clearance in receiving channels (increase to 3/8" [9.5mm] if installing below 40° F [4.4° C]). When the panels are cut in the "V" groove or on the flat surface of the panel to accommodate an opening, install utility trim to properly secure panels, as described above (Figure 58). Check the plumb of the installation every few panels to maintain the best appearance.
- If it will take more than one course to span the height of the house, terminate the first course into an inverted J-channel (Figure 59), allowing 1/4" (6.4mm) for expansion. Install head flashing on top of the J-channel and install a second J-channel facing upward. Begin the second course leaving a 3/8" (9.5mm) gap from the bottom of the panel to the J-channel.
- The final siding panel should be the same width as the starting course. Depending on where the cut occurs, it may be necessary to install utility trim inside the receiving pocket of the J-channel or corner post that receives the vertical siding (Figure 58). It may also be necessary to shim the utility trim outward to a level equal that of the siding panel face, in order to keep a level appearance.

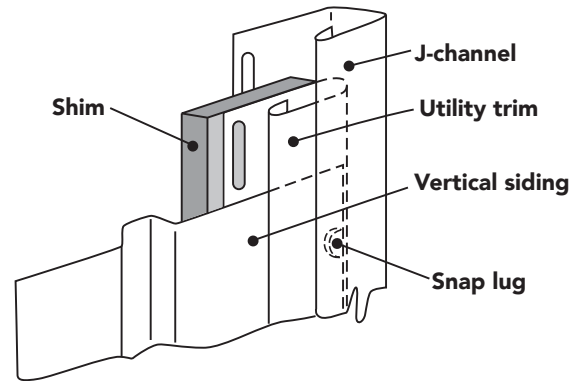

Figure 58

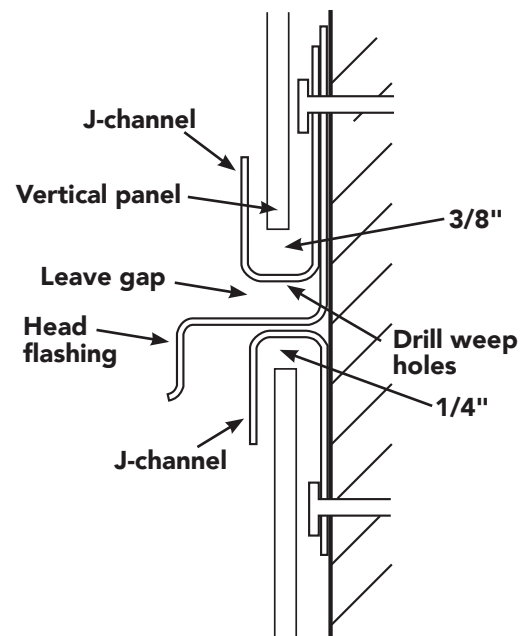

Figure 59

NOTE: It is necessary to drill weep holes in the upper J-channel that are a minimum 3/16" (4.8mm) in diameter no more than 24" (610mm) apart (Figure 59).

VERTICAL SIDING AND ACCESSORIES INSTALLATION

- Cut the panel to the proper width and create tabs every 6" (152mm) using a snap lock punch. Finish the installation by inserting the tabs of the properly sized panel into the utility trim. It may be necessary to place a color-matched trim nail near the top of the panel and inside the J-channel or corner post to keep the partial panel from dropping.
- If you are starting with a full vertical siding panel, you can create a starter strip for vertical siding by cutting the nail hem and adjacent lock off a vertical siding panel. Fasten it inside the receiver channel of the corner post. Another option is to use a standard starter strip. Leave enough clearance in the pocket of the corner post to allow the siding panel to be attached (Figure 60).

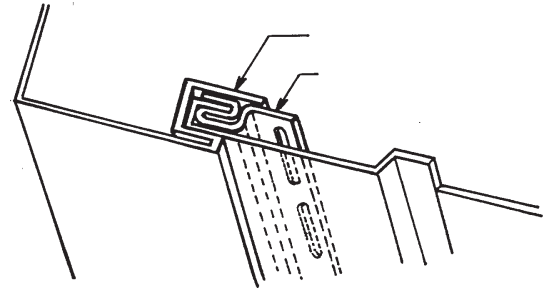

Figure 60

GABLE ENDS

For application of vertical siding to gables, use the same method described in Figure 57 for a balanced appearance.

- Begin by fastening J-channel along the inside edge of the roof. Install an upward-facing J-channel as a vertical base on top of the previously installed J-channel at the base of the gable, as shown in Figure 59. As an alternative, install back-to-back J-channels, centered with the peak of the gable. Install a cut nailing hem as a starter-strip in each J-channel, as described above (Figure 60).
- Make a pattern for end cuts along the gable using two pieces of scrap siding (Figure 61). Lock one piece into the vertical strip at the center of the wall. Hold the edge of the other piece against and in line with the roof line. Mark the slope on the vertical piece and cut along that line. Use it as a pattern to mark and cut the ends of all other panels required for this side of the gable end. Make another pattern for the other side of the gable.

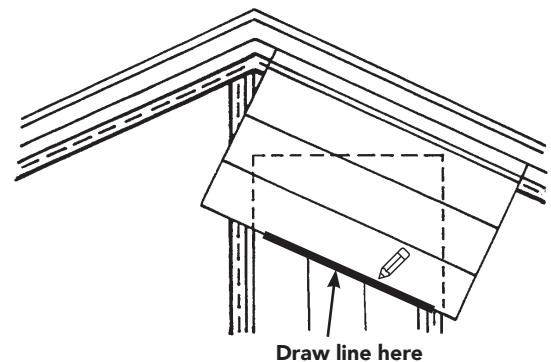

Figure 61

SPECIALTY SIDING

Shake and Shingles: Check specific manufacturer for their installation techniques.

Insulated Vinyl Siding: Fasten the panels in the center of the nailing slots beginning in the center of the panel and working toward the ends (see pages 13 and 14 for specific information on fastening and fasteners).

Be sure that nail length is sufficient to penetrate framing or framing plus nailable sheathing.

SOFFIT INSTALLATION

Soffit is used to enclose the underside of an eave. The installation of soffit will determine the positioning of the inside and outside corner posts. It also is necessary to complete the soffit before the final course of siding is installed on the wall.

Vinyl soffit is designed to be easily installed lengthwise from wall to fascia. Soffit panels are similar to vertical siding. Manufacturers produce both solid and vented panels, as well as combinations of the two.

GABLE PEAK PREPARATION

When transitioning soffit at the peak of a gable (Figure 62), secure two J-channels back to back to receive an individual piece of soffit on each accessory. Alternatively, bend a section of soffit, using a field brake, to match the angle of the peak of the gable.

PREPARATION

Inspect and plan the job in advance. For re-siding applications, nail down any loose panels, boards, or shingles. Check surfaces for straightness and fur when necessary. Surfaces should be uniform and straight from various viewing angles.

The procedure used to install soffit depends on the construction of the eave. There are two different types of eaves:

- **Open eaves**—eaves with exposed rafters or trusses—are typical of new construction. Open eave installation procedures are also used when removing damaged soffit during a re-siding project.
- **Enclosed eaves**—eaves with soffit in place—are typical of re-siding projects.

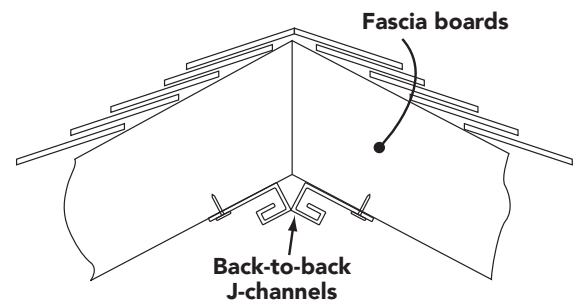

Figure 62

NOTE: Ventilation Requirements

Proper attic ventilation is important for any home. Consult local building codes for the appropriate requirements for a specific geographic area and use vented soffit or other vented products as required. Refer to manufacturer's product specific net free area.

SOFFIT INSTALLATION

INSTALLATION OVER OPEN EAVES

Follow this five-step procedure:

Install receiving channels (J-channel or F-channel).

- There are several ways to install receiving channels for soffit. You can use accessories such as J-channel or F-channel. The best approach is to select a method that works most effectively with the construction techniques used to create the eave.
- Examine the illustrations on the right side of the page and find one that most closely resembles the construction methods used on this particular project (Figures 63–64).
- Install the receiving channels following the details shown in the illustrations on the right. Nail channels every 8" to 12" (203mm to 305mm), positioning the nail in the center of the slot. Do not nail tightly.

NOTE: Nailing strips must be installed as shown in Figure 64 if the eave span is greater than 16" (406mm), unless otherwise specified in the soffit manufacturer's instructions. In areas with high wind restrictions, nailing should not exceed 12" (305mm) on center, unless otherwise specified by the manufacturer.

- If no soffit receiver is available the J-channel can be modified to create an F-receiver (Figure 65).
- Simply cut slots in the nail flange area where it would be nailed to the wall (Figure 65). After cutting the nail flange, bend the flange back and nail it to the wall.
- If the soffit will turn a corner, cut and install the channel so there is 1/4" (6.4mm) for expansion at each of the adjoining walls.

NOTE: Some local codes may require that vinyl soffit be fastened at both fascia and wall. Review the siding manufacturer's instructions and your local building codes for variations that may apply to geographic areas.

NOTE: For more detailed information on installing product in high wind coastal areas, please refer to the How to Properly Install Polymeric Siding and Soffit in Coastal Areas.

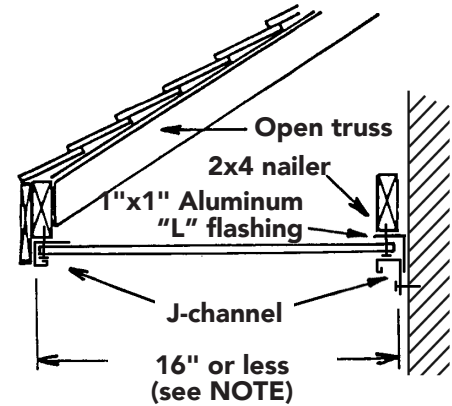

Figure 63

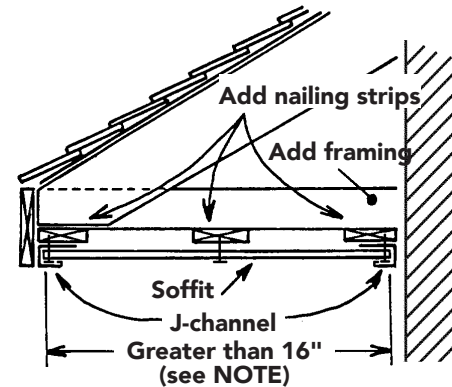

Figure 64

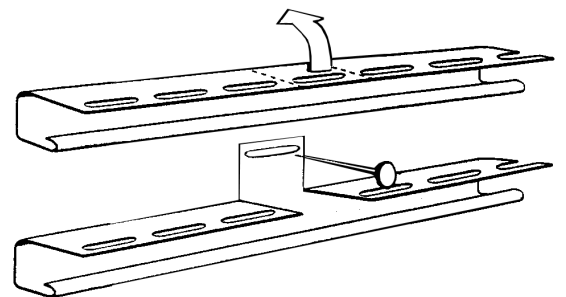

Figure 65

SOFFIT INSTALLATION

Measure from the wall to the fascia board.

- Then subtract 1/2" (12.7mm) to allow for expansion. Mark and cut this dimension on a soffit panel.

In situations with two channels, (Figure 64), flex the panel between the two channels installed.

- It is critical in this application that the installed nailing strips are wide enough (4" [102mm]) to allow a fastener to attach to the soffit. Make sure the panel is perpendicular to the wall when fastening.
- In situations where the soffit panel will be attached at the wood fascia board and then covered with an aluminum fascia cover, each soffit panel should be fastened through the nail hem and either into the wood fascia or into a wood shim using nails, screws, or staples.

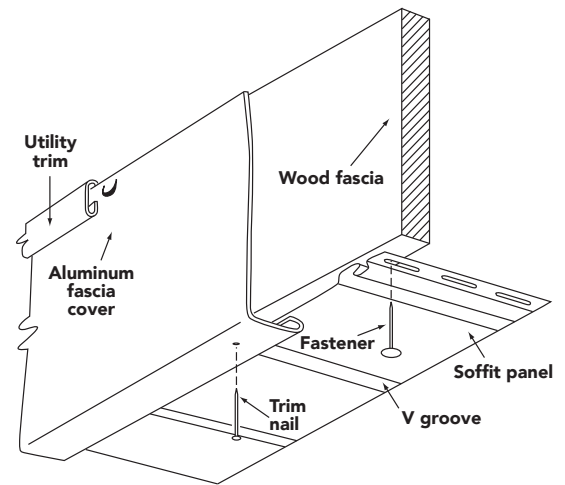

Figure 66

To turn a corner, measure from the channel at the wall corner to the channel at the corner of the fascia board (Figure 67).

- Subtract 1/4" (6.4mm) for expansion. Cut and install soffit double channel lineal or back-to-back J-channel. If necessary, install nailing strips to provide backing for the lineal. Miter cut the corner soffit panels and install as described in Step 3.

Once the soffit has been installed, apply the field- or factory-formed covers.

- The fascia covers can be installed into utility trim (either factory-formed or field-fabricated) (Figure 66) or behind the existing drip edge. The fascia has to be fastened with aluminum or stainless steel painted trim nails into the bottom leg, no more than 24" (610mm) on center.
- When overlapping aluminum/vinyl fascia covers, make sure to overlap 3/4" (19mm).
- Drive these nails through the fascia and only into the "V" groove of the soffit (Figure 66).
- You may also need to face-nail the fascia.
- Always pre-drill holes into fascia and do not nail tight.

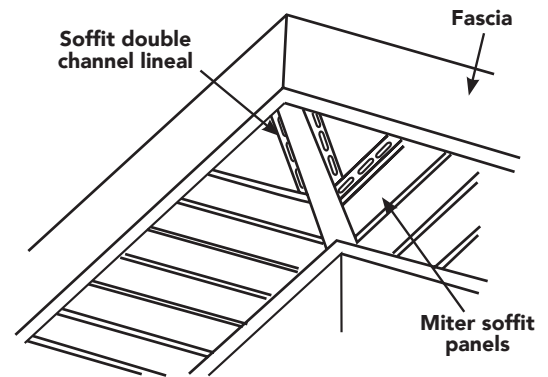

Figure 67

SOFFIT INSTALLATION

INSTALLATION OVER ENCLOSED EAVES

The procedure used to install soffit over an enclosed eave in a remodeling project is almost identical to that used for an open eave in new construction. The major difference is the installation of the J-channel (Figures 68 and 69).

- Determine the preferred method of installing soffit at the fascia board.
- When installing J-channel at either wall of fascia board, nail every 8" to 12" (203mm to 305mm).
- If the soffit is to turn a corner, cut and install J-channel to allow 1/4" (6.4mm) for expansion at each of the adjoining walls and fascia boards.
- When installing vented soffit panels, if the existing soffit doesn't have openings for ventilation, cut an adequate number of openings.
- To complete the installation, follow Installation Over Open Eaves, on page 32.

Other Fascia / Soffit Techniques

- A bird box occurs where an eave and rake overhang intersect. This area should be covered with aluminum trim.
- At fascia inside and outside corners integrate a 1" tab. (Figure 70)

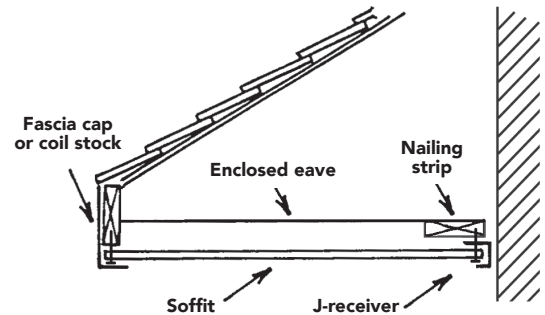

Figure 68

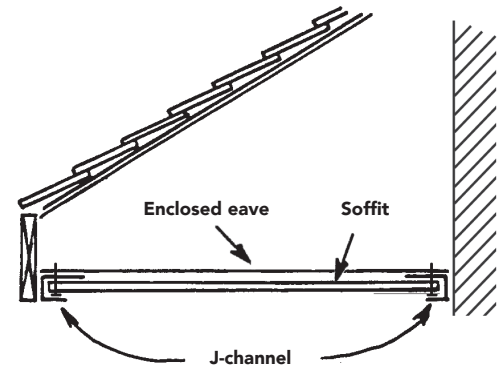

Figure 69

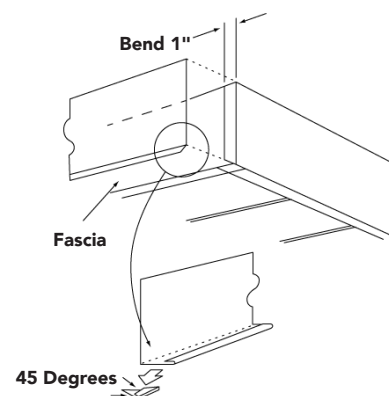

Figure 70

NOTE: These illustrations are based on common installation practices used in most areas of North America. Local environmental conditions (particularly high wind zones) and building codes may call for different installation techniques. Always consult the manufacturer's installation instructions and local building codes to determine the correct installation methods to use on any job. Additionally, refer to the latest version of *How to Properly Install Polymeric Siding and Soffit in Coastal Areas*.

NOTE: If the existing soffit is rotted or damaged, remove it completely before installing vinyl soffit, then use the instructions for open eaves.

SOFFIT INSTALLATION

PORCH CEILINGS

The procedures used to install a porch ceiling are in many ways similar to those used to install soffit. These procedures vary slightly, depending on whether the installation is a new construction or a re-siding project.

New Construction Projects

- **Begin by installing receiving channels on all four sides of the porch (Figure 71).** This can be a J-channel or F-channel. Porch ceiling panel must be fastened at all ends to a supporting component such as a nailing strip. Panels shall be installed in accordance with the manufacturer's installation instructions.
- **When using light blocks to attach external light fixtures, install them to adequate backing.**
- **Plan the layout of the ceiling panels to achieve an even balance or to align with adjacent work.** If the ceiling panels will run parallel to the ceiling joists, additional 1" x 3" (25.4mm x 76.2mm) wood furring nailing strips will have to be installed. Install these nailing strips perpendicular to the ceiling joists, placing a strip every 8" to 12" (203mm to 305mm).
- **Install the first panel into the channels at one end of the porch.** Be sure to leave room for expansion. Nail every 8" to 12" (203mm to 305mm), positioning nails in the centers of slots. Do not nail tightly. Install the remaining panels. When cutting the last panel of the first course, be sure to allow room for expansion.
- **For areas where more than one panel length is needed, use a double channel lineal or back-to-back J-channel.**
- **If it is necessary to cut the nailing hem off the final panel, use a snap lock punch to create tabs every 6" (152mm) along the cut edge.**
Attach utility trim and insert the panel into the receiving channel.

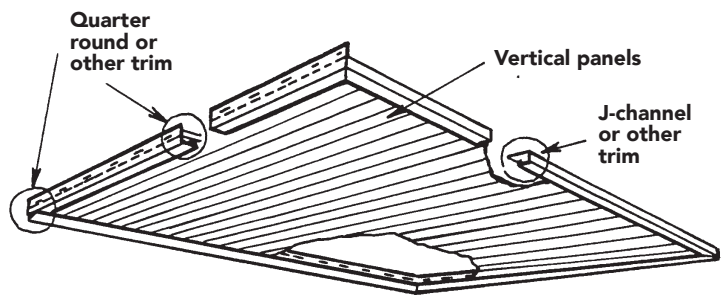

Figure 71

Re-siding Projects

- **Check to be sure the existing ceiling can serve as a solid nailing base.**
- **If the existing ceiling is solid, remove all existing moldings and fixtures from the ceiling and begin by nailing inverted J-channels along the perimeter of the ceiling area.** Then follow Steps 2 through 6 in the instructions under "New Construction Projects." With a solid ceiling, however, additional nailing strips are not necessary. Use the existing ceiling as the nailing base for the panels.
- **If the existing ceiling is not solid, install nailing strips to provide a secure nailing base, then install the J-channels.** Additional nailing strips should be installed if the ceiling panels are to run parallel to the ceiling joists. Follow the instructions in Steps 2 through 6 for new construction.

OTHER RECOMMENDATIONS

ATTACHING SHUTTERS AND OTHER SPECIALTY PRODUCTS

To install shutters around windows:

- Pre-drill holes through the shutters for attachment screws and mark the location of these holes on the siding (Figure 72).
- Using the hole marks as a guide, drill expansion holes through the siding where attachment screws will be located, a minimum 1/4" (6.4mm) larger than the diameter of the screw (Figure 73).
- When attaching the shutters, do not fasten such that the shutter is tight against the siding, otherwise expansion of the siding will be restricted.
- When it is necessary to attach any specialty item, for example down spouts, drill a hole that is 1/4" (6.4mm) larger than the fastener shank diameter to allow the vinyl panel to move with temperature changes.

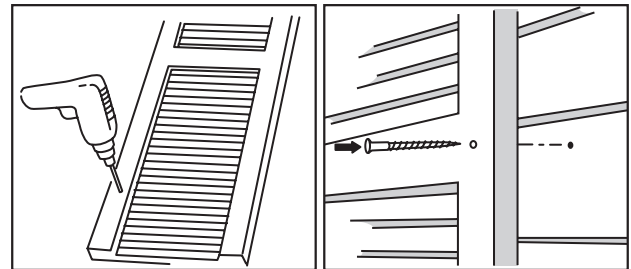

Figure 72

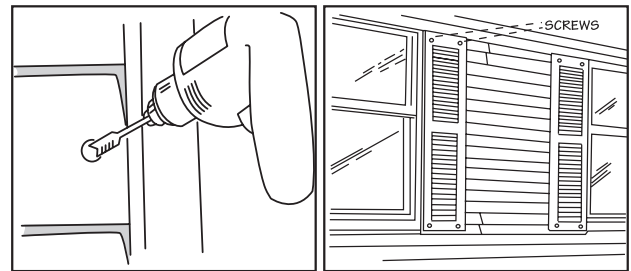

Figure 73

REPLACING A DAMAGED PANEL

To remove a panel for any reason:

- Slip the zip lock or unlocking tool behind the bottom of the panel above the one to be replaced and unzip it from the lock on the damaged panel (Figure 74).
- Gently bend out the upper panel. Take the nails out of the damaged panel and remove it (Figure 75).
- Lock on the new panel and nail it up (Figure 76).
- Use the unlocking tool again to zip the upper panel over the lock on the new panel (Figure 77).

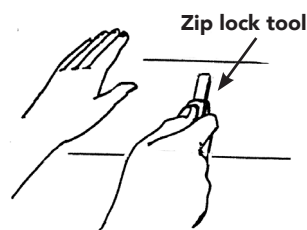

Figure 74

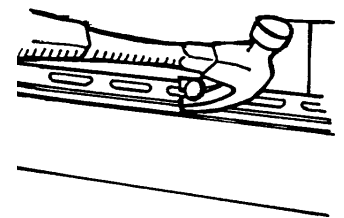

Figure 75

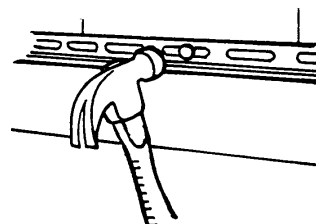

Figure 76

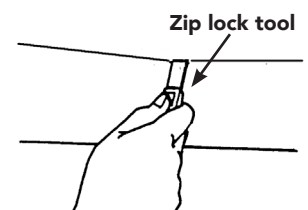

Figure 77

OTHER RECOMMENDATIONS

REPAIRING A DAMAGED CORNER POST

Repair a damaged corner post with a series of cuts:

- Cut away the face of the damaged corner, leaving the nail hem and pocket intact.
- Remove the nailing hem from the replacement corner (Figure 78).
- Place the new corner over the remaining portions of the old one and fasten it into position with one rivet on either side located at the top of the post.

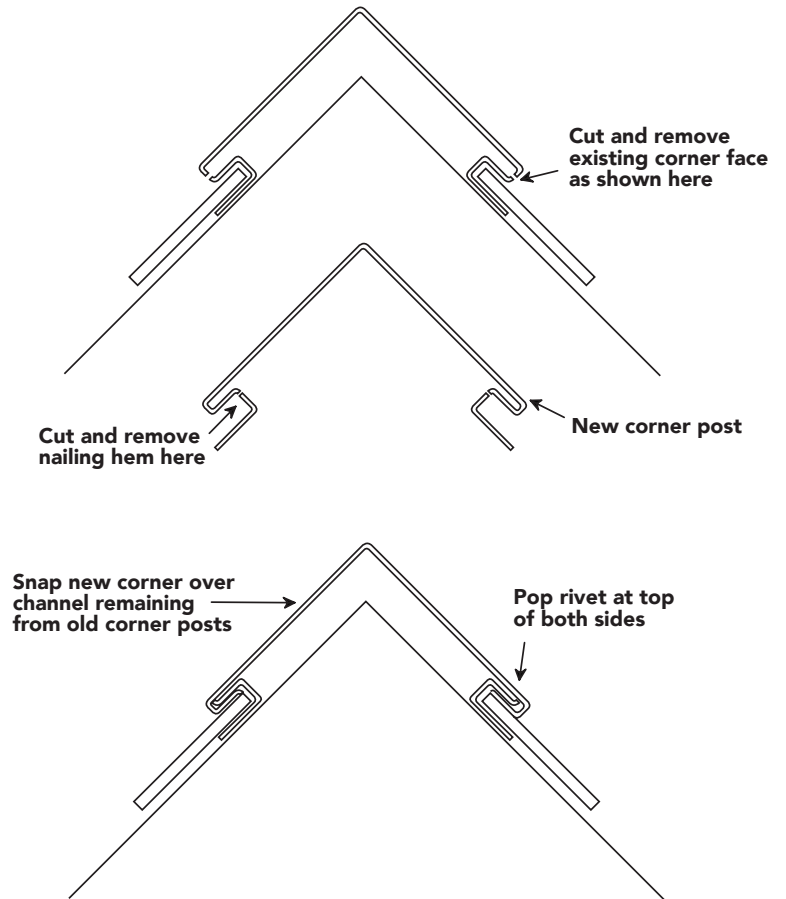

Figure 78

OTHER RECOMMENDATIONS

BENDING TRIM SHEET

- Window and door trim is often covered with trim sheet.
- Many of the accessories used for siding installation can be made on a brake.
- Trim sheet can be either aluminum or vinyl.

WINDOW SILL WITH BUILT-IN UNDERSILL

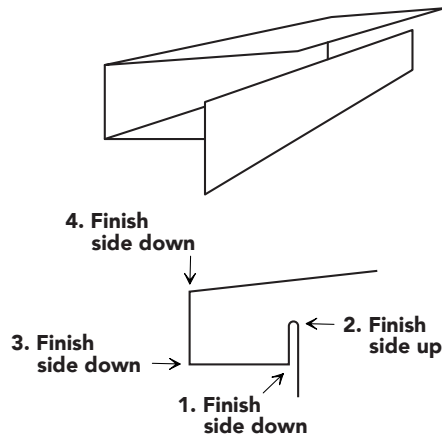

Figure 79

F-CHANNEL OR INSIDE CORNER

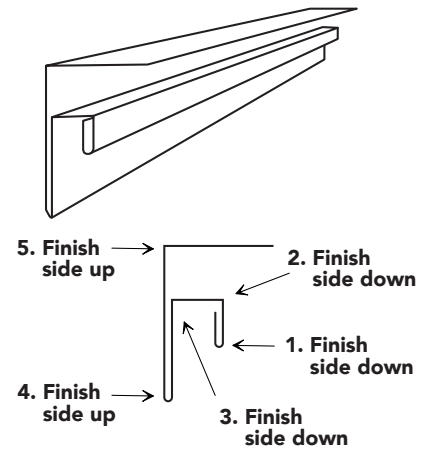

Figure 80

WINDOW SILL WITH BUILT-IN UNDERSILL

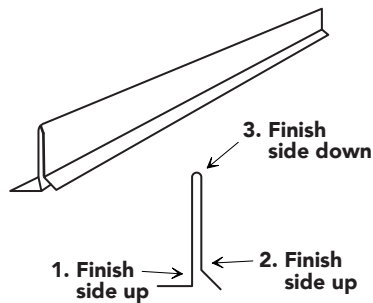

Figure 81

WINDOW/DOOR CASING WITH BUILT-IN J-CANNEL

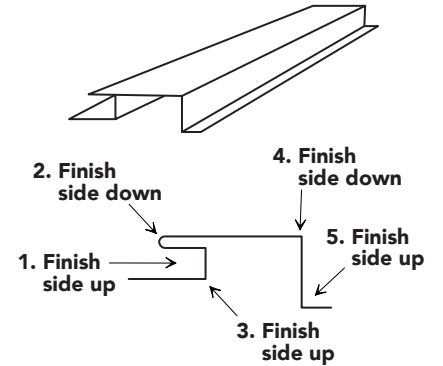

Figure 82

USING DRAWINGS

The drawings from the brake manufacturer:

- Show the order of the bends.
- Show if the finish side of the sheet should be facing up or down when making each bend.
- Show where hems should be added for all exposed edges.

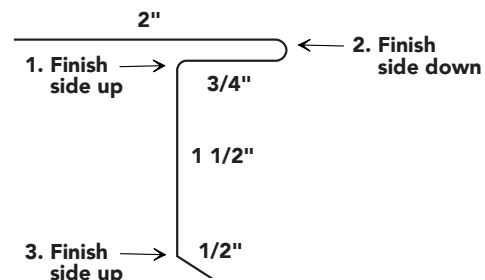

Figure 83

OTHER RECOMMENDATIONS

MEASURING

- Measure the object that is being covered and determine if receiving pockets will be needed.
- If the face of the shape is especially wide, bends may need to be made to add stiffness.
- Add material for each inside bend and any additional bends.

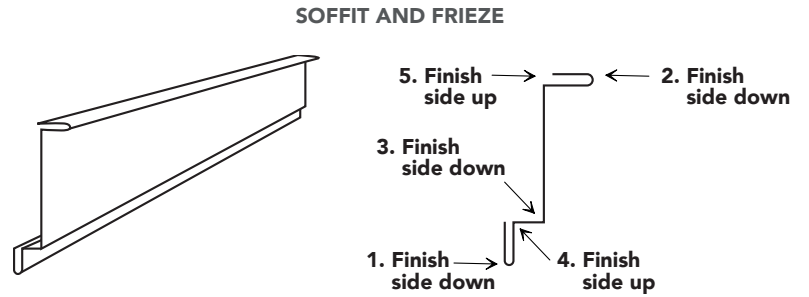
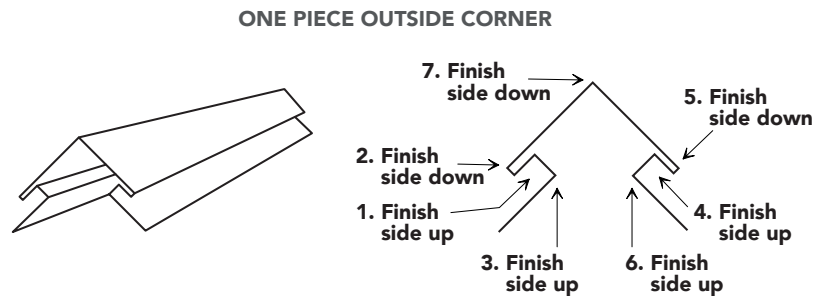

Figure 84



NOTE: Minimum width possible 2 1/4"

Figure 85

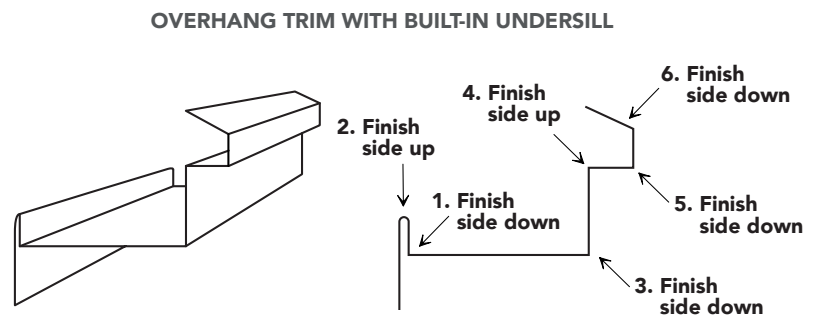

Figure 86

OTHER RECOMMENDATIONS

CUTTING AND BENDING

- Make a trial piece with scrap trim sheet.
- Cut trim sheet with snips, a brake cutter, or by scoring the face and bending.
- Bend hems first.
- Usually start in the middle of the sheet and work toward the edges.

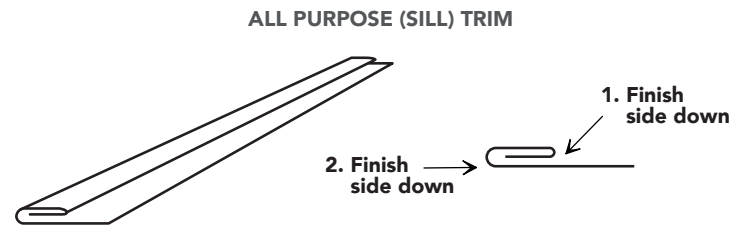

Figure 87

ATTACHING TRIM SHEET

- Apply the lower pieces of trim sheet first (weatherboard fashion).
- Make tabs so they go under upper pieces.
- Attach pieces with aluminum or stainless steel color-matched trim nails.
- Place nails in inconspicuous locations.
- Pre-drill the nail holes through the trim sheet. The nail holes should be larger than the nail shank, but smaller than the nail head.
- Don't drive the nails tight.

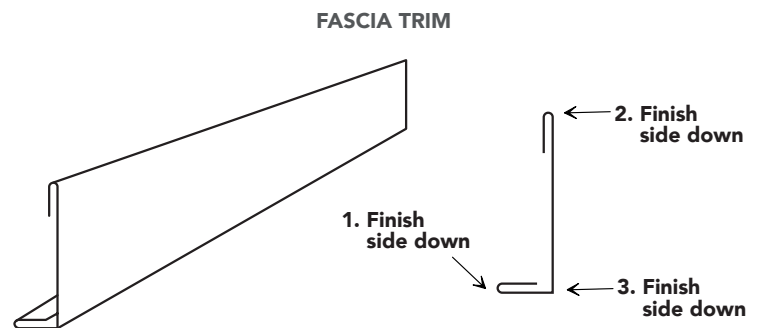

Figure 88

INSTALLING TRIM WITH BUILT IN J-CHANNEL AROUND WINDOWS

- Apply the sill piece of J-channel first. Fasten every 8" to 12".
- Attach the jamb pieces next. The tabs of the jamb pieces go into the notches of the sill piece.
- Attach the head J-channel last. The tabs of the head piece go into the notches of the jamb pieces.

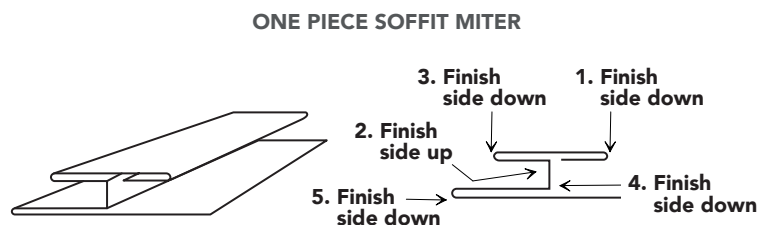

Figure 89

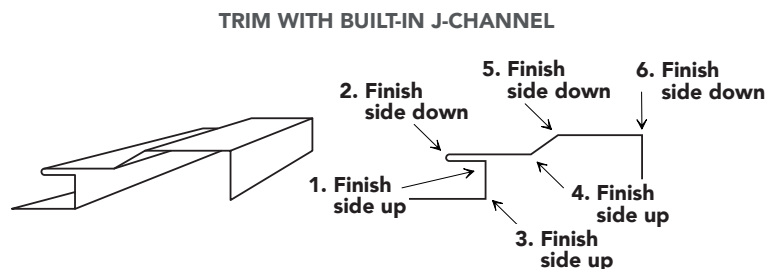

Figure 90

TERMS TO KNOW APPENDIX 1

Bird Box: location where the Eave and the Rake intersect.

Building Codes: a series of ordinances enacted by a state or local governmental entity, establishing minimum requirements that must be met in the construction and maintenance of buildings.

Buttlock: the bottom edge of a siding or soffit panel, or accessory piece, opposite the nailing slots, which locks onto the preceding panel.

Channel: the pocket of the accessory trim or corner post where siding or soffit panels are inserted. Channels also refer to the trim itself and are named for the letters of the alphabet they resemble (e.g., J-channel, F-channel, etc.).

Course: a row of panels, one panel wide, running the length of the house from one side to the other, or, in the case of vertical siding, from top to bottom.

Diverter (Kick Out Flashing): kick-out flashing prevents water from running down a roof and ending up behind the siding on an adjacent wall.

Drip Cap/Head Flashing: an accessory installed to ensure that water is directed away from openings/penetration points.

Double Channel Lineal: a siding accessory that joins two soffit panels.

Face: refers to the side of a siding or soffit panel that is showing once the panel has been installed.

Face-nailing: the action of fastening directly onto the “face” side of a panel (instead of using the nail hem slot). This practice is generally not used in vinyl siding installation.

Fascia Board: the trim (mostly wood) that covers the ends of roof rafters.

Fascia Covering: the Fascia Covering (either factory formed or field-fabricated) covers the wood Fascia Board (Figure 66).

Flashing: thin pieces of impervious material installed to prevent the passage of water into a structure from a joint or as part of a water-resistive barrier system.

Furring/Furring Strip: usually a wood strip used to even a surface in preparation for installing vinyl siding. Furring Strips can also be used to attach vinyl siding to a non-nailable surface.

Historic Restoration: is the action or process of accurately revealing, recovering or representing the state of a historic building, as it appeared at a particular period in its history, while protecting its heritage value.

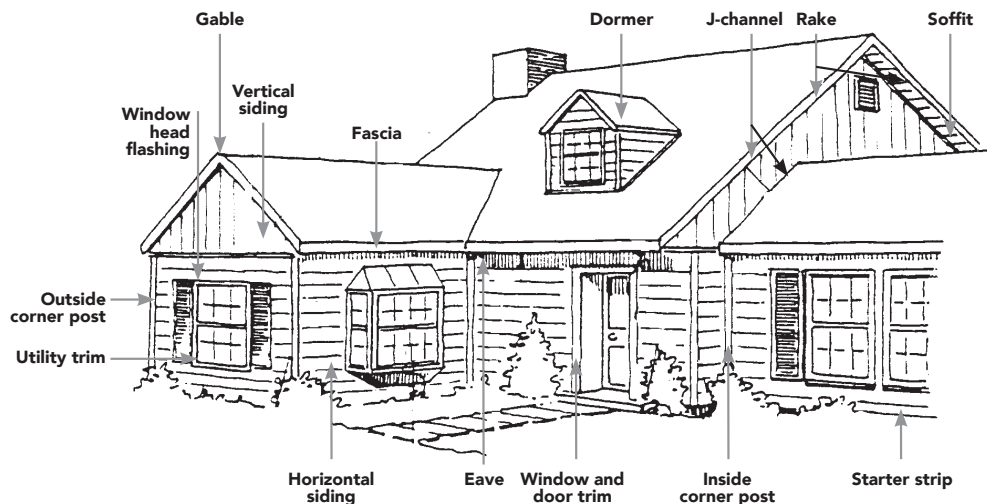

Figure 91

TERMS TO KNOW APPENDIX 1

Lap: to overlap the ends of two siding panels or accessory pieces to allow for expansion and contraction of the vinyl product.

Lug/Crimp: the raised “ears” or tabs on a siding panel, created by a snap lock punch, which can be used to lock a siding panel into place when the nailing hem has been removed.

Metal Brake: a brake is a metalworking machine that allows the bending of sheet metal.

Miter: to make a diagonal cut, beveled to a specific angle (usually 45°). Sometimes miter cuts are made into an overlapping siding or soffit panel surface, to provide a neater appearance.

Mounting Block: provide multiples uses, including the ability to easily and attractively mount light fixtures, water faucets, receptacles, and the like.

Nail Hem (or Flange): the section of siding or accessories where the nailing slots are located.

Nailing Strip: an additional framing member installed to facilitate soffit installation.

Nail Hole Slot Punch: refer to Figure 7 for illustration and use.

Plumb: a position or measurement that is truly and exactly vertical.

PVC (Polyvinyl Chloride): a common, strong but lightweight plastic used in construction. It is made softer and more flexible by the addition of plasticizers.

Rake (roof): the inclined, usually projecting edge of a sloping roof.

Rake (wall): the board or molding placed along the sloping sides of a gable to cover the ends of the siding.

Scoring: running a utility knife blade, sharpened awl, scoring tool, or other sharp implement across a soffit or siding panel face without cutting all the way through the panel. This weakens the vinyl siding surface in a specific area and allows the panel to be bent and broken off cleanly.

Sealant: A compound used to fill and seal a joint or opening.

Sheathing: can be wood, foam or other materials. It comes in various thicknesses. The most common sheathing is wood, this is either plywood or OSB (oriented strand board).

Shim: a thin, sometimes often tapered piece of material (such as wood, or foam metal, or stone) used to even a surface prior to installing vinyl siding.

Shutter: a solid or louvered movable or stationary cover or fixture for a window.

Snap Lock Punch: refer to Figure 7 for illustration and use.

Soffit: material used to enclose the horizontal underside of an eave and gable.

Starter Strip: an accessory typically used at the bottom of all walls to lock the first course of siding.

Underlayment: water-resistive material placed under vinyl siding panels.

Utility Trim: a piece of trim used any time the top lock has been removed from the siding, to secure a siding panel. Also referred to as “undersill” or “finish” trim; double utility trim is also available.

Water-Resistive Barrier: a material applied between the sheathing and the siding that is intended to resist any water that penetrates through the siding and meets the requirements of ICC AC38.

Weep Holes: openings placed into siding or accessories to allow for water drainage.

Wind Load: the force on a structure arising from the action of wind on it.

Zip Lock Tool: also known as an unlocking tool; refer to Figure 7 for illustration and use.

ACRONYMS APPENDIX 2

PVC: Poly Vinyl Chloride

ASTM International: (Formerly called American Society for Testing and Materials)

VSI: Vinyl Siding Institute

IRC: International Residential Code

IBC: International Building Code

NBC: National Building Code of Canada

WRB: Water-Resistive Barrier

IECC: International Energy Conservation Code

NRCC: National Residential Council of Canada

OSB: Oriented Strand Board

ICC: International Code Council

OSHA: Occupational Safety Health Administration

DESIGN.
BUILD.
LIVE.
NO LIMITS.

vinylsiding.org

1800 Diagonal Road, Suite 545, Alexandria, VA 22314

©2020, Vinyl Siding Institute, Inc.

