

ARCHITECTURAL POLYMERS:

BEST PRACTICES FOR ARCHITECTURAL SPECIFICATIONS

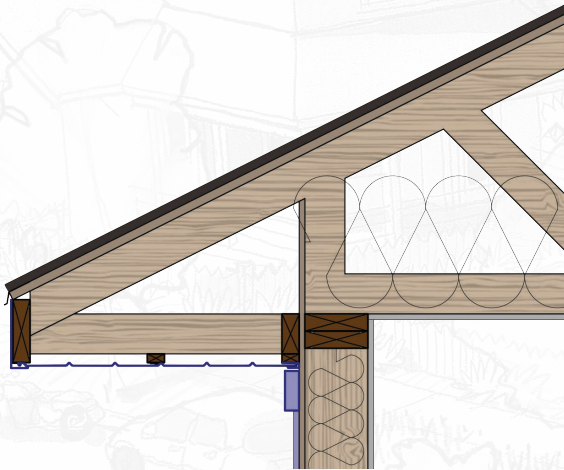

Written by Fernando Pagés Ruiz

Architectural Drawings by Dana Johnson

Book design by Pel-Ona Architects and Urbanists

Edited by Peter Chapman

Published by Vinyl Siding Institute

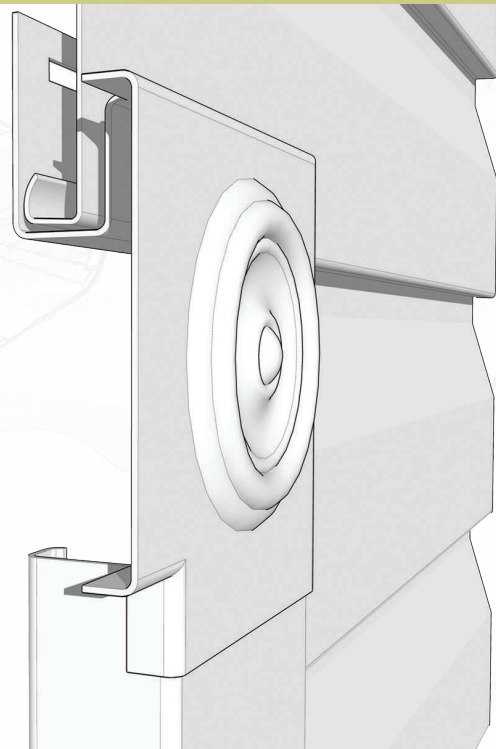

ARCHITECTURAL POLYMERS:

BEST PRACTICES FOR ARCHITECTURAL SPECIFICATIONS

Published by VINYL SIDING INSTITUTE

Written by **Fernando Pagés Ruiz**

Architectural drawings by **Dana Johnson**

Book design by **Aly Burkhalter and Pel-Ona Architects & Urbanists**

Edited by **Peter Chapman**

© 2021 Vinyl Siding Institute, Inc.

For more information on all Vinyl Siding Institute publications
visit our website: www.vinylsiding.org

ISBN-13: 978-1-7333256-1-5

Table of Contents

HOW TO USE THIS BOOK, p. iv

FOREWORD, p. v

PRODUCT AND INSTALLER CERTIFICATIONS, p. vi

CHAPTER 1 PROFILE CONSIDERATIONS, p. 1

- I. Cladding Profiles, p. 2
- II. Polymer Technology, p. 10
- III. Color, p. 11
- IV. Texture, p. 11

CHAPTER 2 TRIM, p. 13

- I. Functional Trim, p. 14
- II. Head Trim, p. 16
- III. Vertical Casing, p. 17
- IV. Windowsills, p. 17
- V. Corners (Inside/Outside), p. 18
- VI. Horizontal Bands, p. 19
- VII. Cornice (Top-of-Wall Trim), p. 20
- VIII. Fascia, p. 20
- IX. Specialty Trim, p. 21

CHAPTER 3 ORNAMENTS, p. 23

- I. Brackets, p. 24
- II. Rosettes, p. 24
- III. Dentils, p. 25
- IV. Composite Crown, p. 26
- V. Keystones, p. 26
- VI. Pediments, p. 27
- VII. Columns and Posts, p. 27

CHAPTER 4 WORKAROUNDS, p. 29

- I. Camouflaging J-Channel, p. 30
- II. Compensating for Thin Millwork Edges, p. 31
- III. Simulating Butt Joints, p. 32
- IV. Avoiding Stacked Seams, p. 33
- V. Diminishing Wedge-Shaped Shadow Lines, p. 33
- VI. Transitioning from Horizontal to Vertical, p. 34
- VII. Mitered Outside Corner Options, p. 35
- VIII. Inside Corner Options, p. 36
- IX. Alternatives to Penetration Box-Trim, p. 37
- X. Soffit Construction, p. 38
- XI. Fascia Construction, p. 39
- XII. Architrave Construction, p. 40
- XIII. Eave Return, p. 41

APPENDIX, p. 43

How to Use This Book

In this printed version of the book, [blue](#) font denotes a downloadable file. Go to vinylsiding.org/APS for the interactive PDF version of the book to download zip folders containing files for your construction details. Hyperlinks denoted “[i](#)” contain SketchUp components you can manipulate and add to your own drawings or models, and may contain an AutoCAD profile drawing. Hyperlinks denoted “[DWG](#)” contain annotated AutoCAD files for construction drawings but no sketchup model. In addition, you will find downloadable material specifications to tailor to your needs and links to environmental, health-safety, and building code resources in the appendixes.

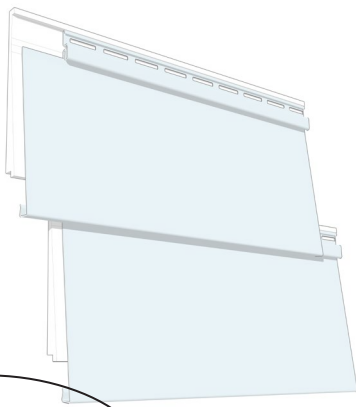

CLICK [BLUE](#) TEXT TO
DOWNLOAD SKETCH-
UP MODEL, AUTOCAD
PROFILE & JPEG

Figure 6 ([i-6](#)): Composite assembly of two horizontal insulated clapboard single 7-inch panels. These panels have a flat face.

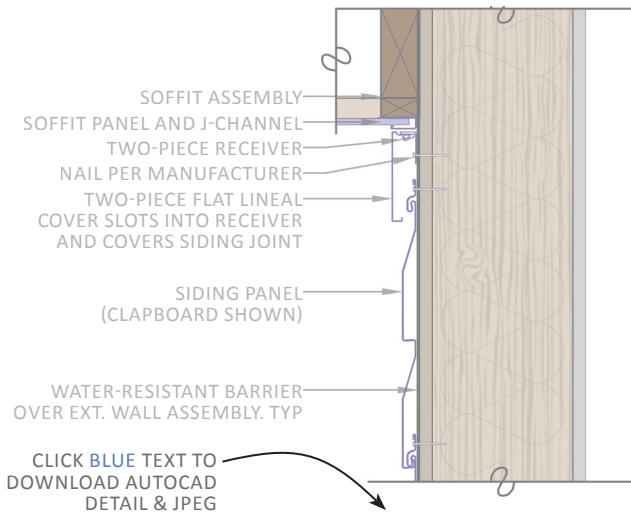

Figure 112 ([DWG-112](#)): Top-of-wall termination.

Foreword

This document serves as a resource for product specification and complements the book [Architectural Design for Traditional Neighborhoods](#) published by the Vinyl Siding Institute (VSI) in 2019.

The material options presented aim to provide design professionals full control of the design's aesthetic outcome with polymeric sidings, trim, and ornamentation, respecting the architectural style, target market, and project budget.

These specifications will refer to traditional architectural features in the language of art. Although applicable for builders, the document addresses architectural designers.

We also provide necessary installation details drawn from the *VSI Installation Manual* so that design professionals can specify best practices in the craft.

This effort aims to put the power of good design details and recommended installation practices within the architectural designer's easy reach.



Figure 1: Polymeric claddings and trim come in sufficient varieties and colors to clad many traditional building styles, such as this Folk Victorian home. The columns and trims in the photo are cellular PVC while the siding is vinyl clapboard.

Product and Installer Certifications

Vinyl siding is the only cladding material that offers a complete certification program run through the Vinyl Siding Institute. This certification encompasses material manufacture and performance that meet or exceed ASTM standards. Products that appear on this list have completed or exceeded all the requirements of ASTM D3679 for vinyl siding, ASTM D7793 for insulated vinyl siding, or ASTM D7254 for polypropylene siding, as verified by an independent quality control agency. Quality control includes unannounced plant inspections twice each year. In addition, certified Vinyl Siding Installers understand how to correctly fasten siding to allow for vinyl's normal expansion and contraction properties. They know how to keep vinyl siding straight and secure on walls and properly prepare areas around doors, windows, and other openings to prevent water infiltration. At the time of publication, over 5,000 installers hold VSI's certification.



CERTIFICATION PROGRAM

Figure 2: Vinyl siding comes with third-party certification standards for material (vinyl and polypropylene), insulation, and color. Unique to vinyl siding, the Vinyl Siding Institute runs an installer certification program with nearly 5,000 trained installers throughout the US.



Figure 3: The Vinyl Siding Institute runs a Certified Installer Program for skilled vinyl siding installers that involves at least two years of installation experience, a class to train in-person with a certified instructor and prepare for the exam, and passing an exam that tests their knowledge about vinyl siding installation and industry-recognized installation standards according to ASTM D4756.

Chapter 1

Profile Considerations

IN THIS CHAPTER

The manufacturers of polymeric claddings offer a broad range of siding types and styles. From clapboard to beaded siding and chamfer to ledgerstone, this chapter describes the most popular profiles and defines the materials used in their fabrication. Not all manufacturers make all the products, and new styles and colors come into the market every year. Yet the types of siding presented here cover the typical palette of claddings used in traditional neighborhood design. With the drafting tools provided in the [blue](#) hyperlinks, a designer can represent the materials accurately in details and renderings.

I. CLADDING PROFILES

HORIZONTAL

- HORIZONTAL CLAPBOARD
- HORIZONTAL BEADED
- HORIZONTAL DUTCH LAP

SPECIALTY

- SHAKE
- SHINGLE

SOFFIT

VERTICAL

- BOARD-AND-BATTEN
- OTHER VERTICAL SIDINGS

OTHER MATERIALS

- STONE/MASONRY

II. POLYMER TECHNOLOGY

- VINYL SIDING
- INSULATED VINYL SIDING
- POLYPROPYLENE SIDING
- SOLID CELLULAR PVC SIDING
- SOLID CELLULAR PVC TRIM/ORNAMENTS
- OTHER POLYMERIC INNOVATIONS

III. COLOR

IV. TEXTURE

I. CLADDING PROFILES: HORIZONTAL

HORIZONTAL CLAPBOARD

Also called beveled siding and weatherboard, traditional clapboard comes in vinyl, polyash (polyurethane siding), and cellular-PVC materials. Course widths range from 3 inches to 8 inches, and panel lengths vary from 12 feet to 25 feet. Most material comes in two- to three-course panels, although

some wider planks present single courses. Material thickness averages 0.044". While finishes typically represent a wood-grain texture, you can also find some with brushstroke and smooth. The material comes with and without insulating foam backing.

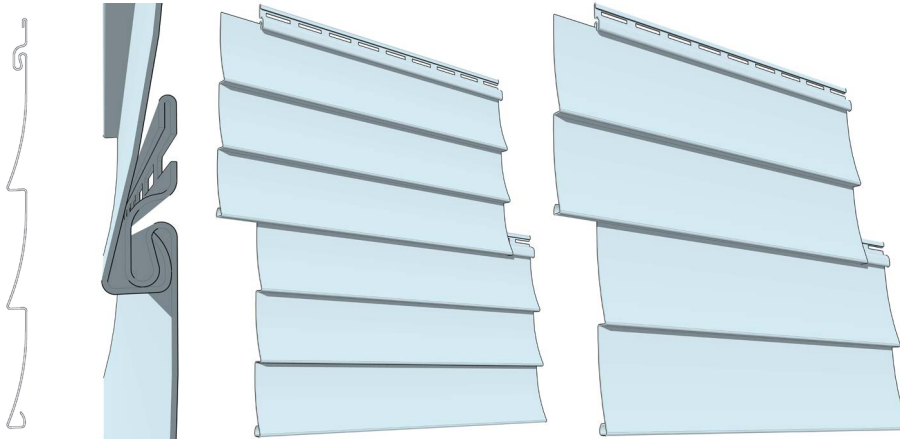

Figure 4 (i-4a, i-4b, i-4c): From left to right: a horizontal clapboard triple 3-inch vinyl panel profile; a typical joint between two horizontal clapboard vinyl panels; and a composite assembly of two horizontal clapboard triple 3-inch panels.

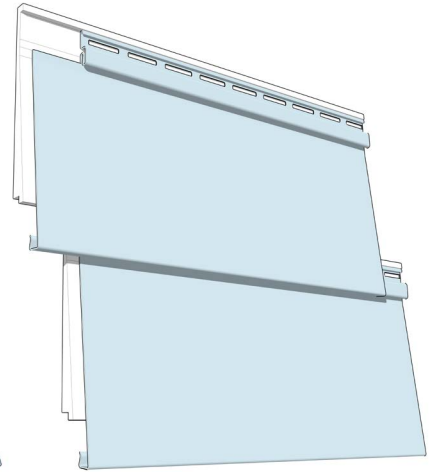

Figure 5 (i-5): Composite assembly of two horizontal clapboard double 4-inch panels.

Figure 6 (i-6): Composite assembly of two horizontal insulated clapboard single 7-inch panels. These panels have a flat face.

HORIZONTAL BEADED

Beaded vinyl siding replicates the traditional cladding of the antebellum homes in the South. It has a rounded bead running along the bottom and a deep V-groove that casts well-defined, parallel shadow lines between the panel's face and the bead. Beaded siding comes in 12-foot lengths

and single-course panels of 6.5 inches in width. Material thickness averages 0.044". Most panels have a brushstroke finish, never wood grain. The material comes with and without insulating foam backing.

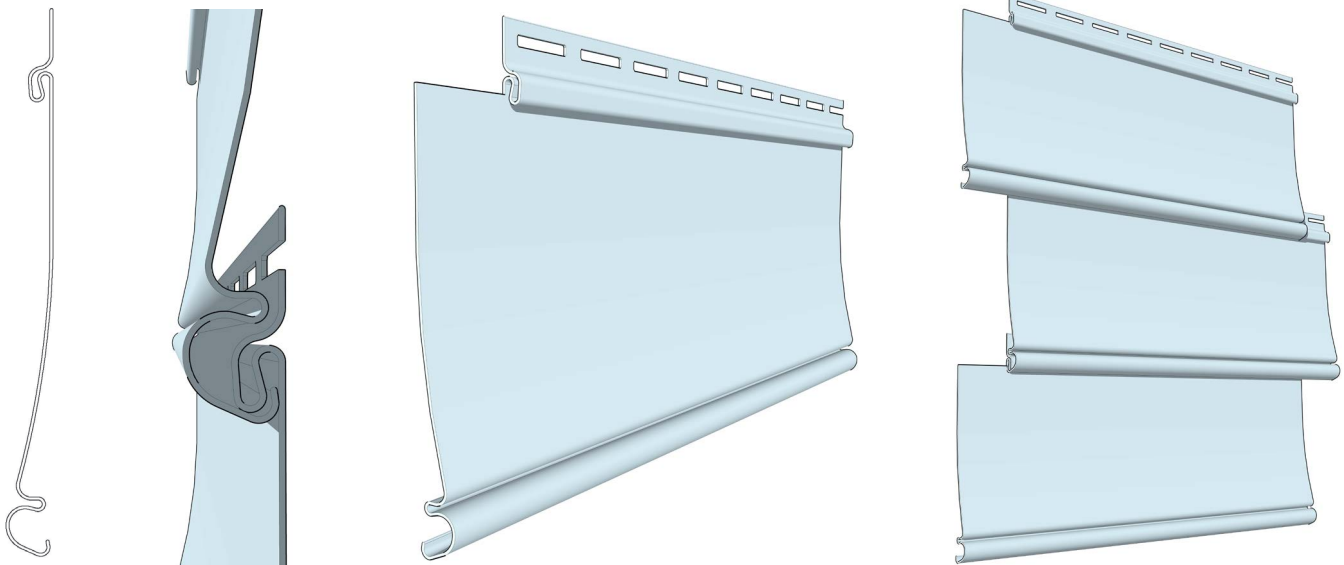

Figure 7 (i-7a, i-7b, i-7c, i-7d): From left to right: a horizontal beaded single 6.5-inch vinyl panel profile; a typical joint between two extruded horizontal beaded single 6.5-inch vinyl panels; a section of a single piece of paneling; and a composite assembly of three horizontal beaded single 6.5-inch panels.

HORIZONTAL DUTCH LAP

Also known as cove lap or German siding, this style of drop siding has no angle on the face but an edge eased to create the appearance of European shiplap or tongue-and-groove siding. Course widths range from 4 inches to 6 inches, with panel lengths that go from 12 feet to 25 feet. Panels most

often include two to three courses, and material thickness averages 0.044". Most material comes with a wood-grain texture and is available with and without insulating foam backing.

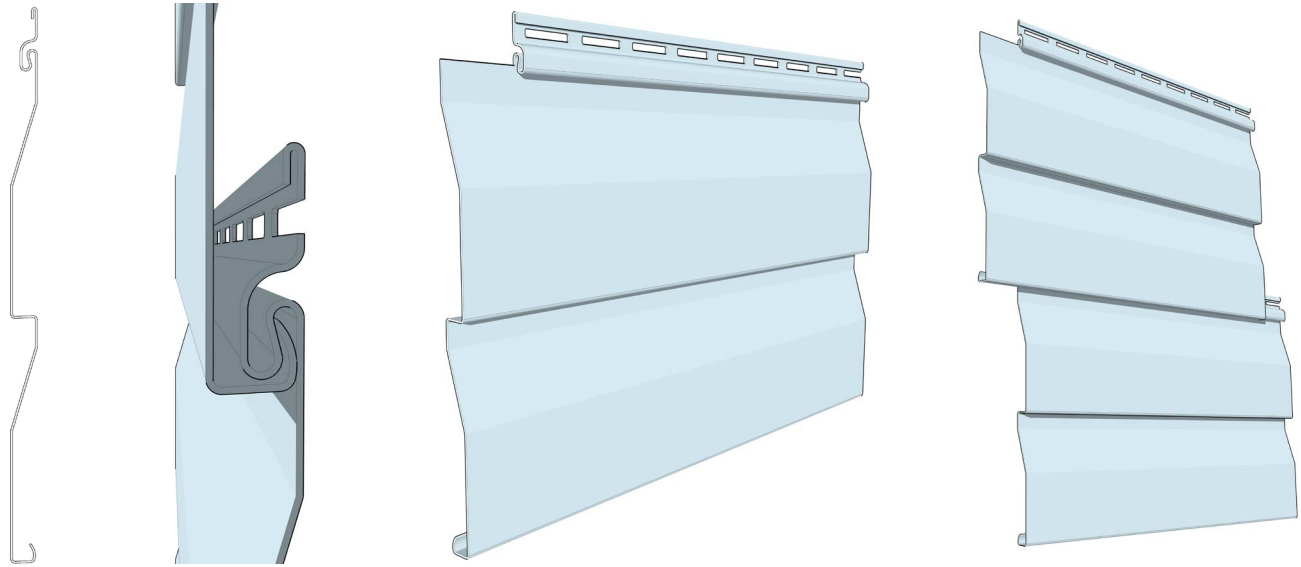

Figure 8 (i-8a, i-8b, i-8c, i-8d): From left to right: a horizontal Dutch lap double 5-inch vinyl panel profile; a typical joint between two horizontal Dutch lap double 5-inch vinyl panels; a section of a single piece of paneling; and a composite assembly of two horizontal Dutch lap double 5-inch panels.

EXEMPLARY ARCHITECTURAL APPLICATION

Throughout this book you will see examples of exemplary architecture created with leading design firms that have selected polymeric cladding. Take note of the variety of styles and how these designers used these materials to create attractive buildings and neighborhoods. The examples below include residential designs in two New Urbanist neighborhoods designed by DPZ CoDesign and Torti Gallas + Partners.



Figure 9: Example of horizontal beaded vinyl siding at the Lakelands Neighborhood, Gaithersburg, MD, by DPZ CoDesign.



Figure 10: Example of horizontal Dutch lap vinyl siding at Lantern Hill, Doylestown, PA, designed by Torti Gallas + Partners.

CLADDING PROFILES: SPECIALTY

SHAKE

Shake siding in vinyl, polypropylene, and cellular-PVC mimics the traditional cladding made from split logs. A great variety of sizes, textures, and colors exist. Most shake face exposures range from 7 inches to 10 inches. Textures range from the rugged split to heavily grooved shingles.

Some shake siding comes with staggered ends to reproduce hand-hewn material more accurately. Colors vary, with many brands presenting variegated tones. Individual panels typically range from 3-foot to 5-foot widths. Seams remain invisible. Manufacturers do not offer an insulated shake.

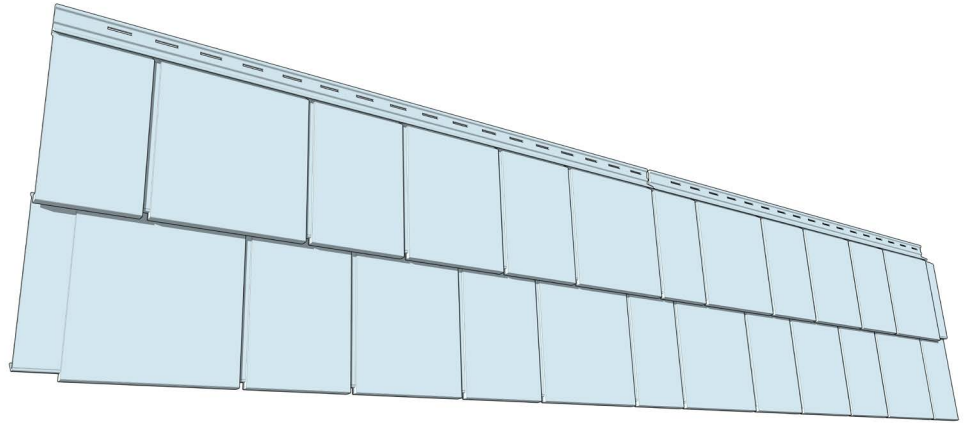
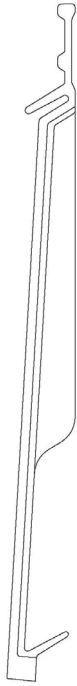

Figure 11 (i-11): A shake polypropylene profile.

Figure 12 (i-12): A composite assembly of two split shakes with even edge panels.

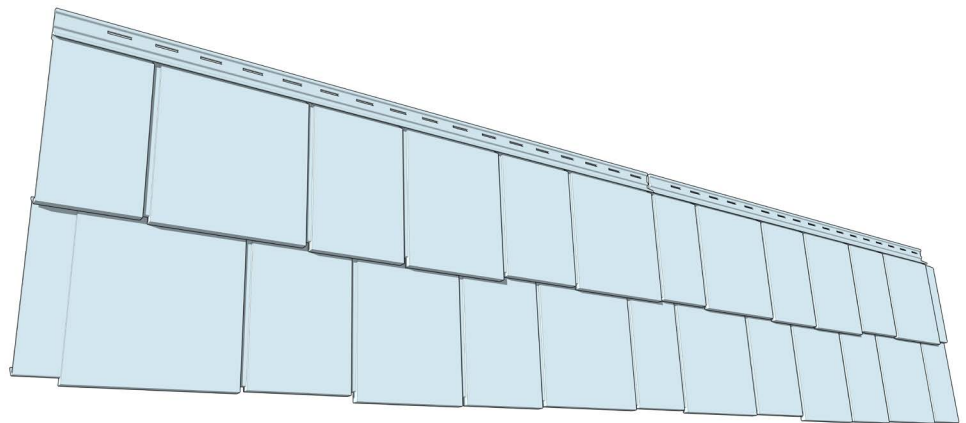
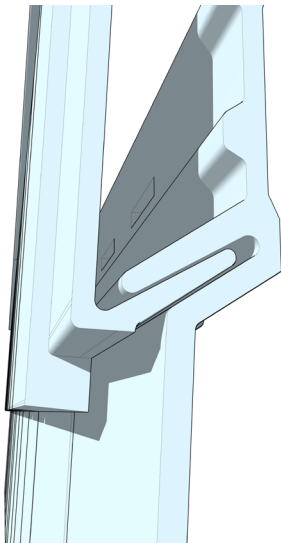

Figure 13 (i-13): A typical joint between two polypropylene split shakes

Figure 14 (i-14): A composite assembly of two staggered shake panels.

SHINGLE

Shingles became the manufactured alternative to shakes in the late 1800s. Due to the wide variety of shingle shapes, this cladding came to express the builder's creativity. Flamboyant examples include Shingle Style gable ends, Eastlake Style Queen Anne, and Folk Victorian homes. All the polymeric materials represent shingles well, and a wide variety of

styles exist, including (but not limited to) hexagon, scallops, mitered, and square. All shingle profiles include a vertical grain pattern that effectively represents the wood material. Some manufacturers of polypropylene shingles also make strikingly modern patterns that resemble the steel siding popular on contemporary homes and commercial buildings.

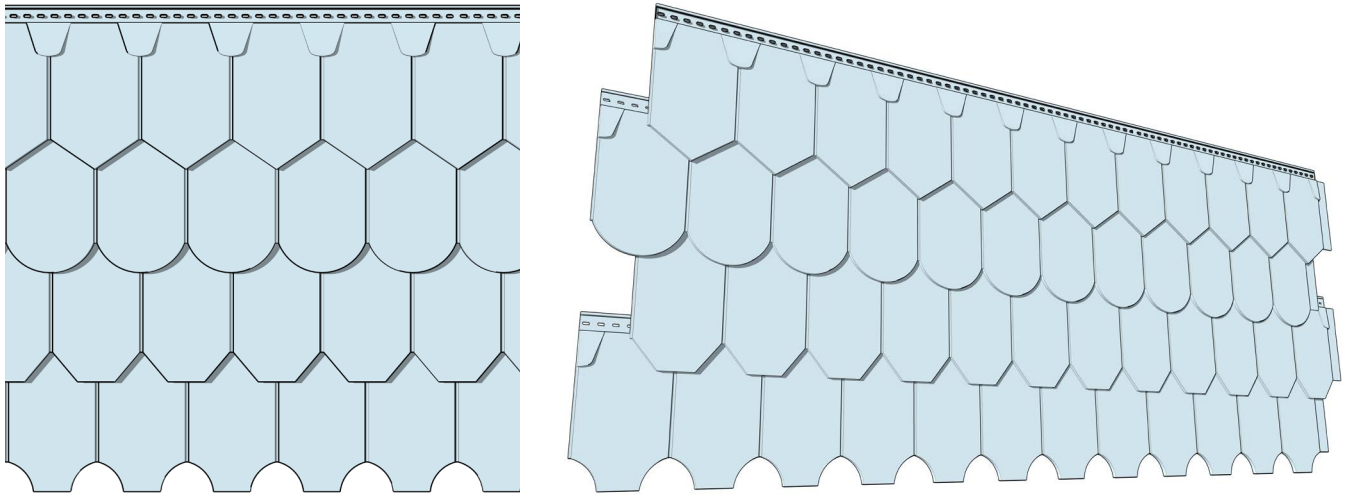

Figure 15 (i-15a, i-15b): At left, a composite assembly of shingle vinyl panels with the following four shapes from top to bottom--hexagon, round/scalloped, octagon/mitered, and half cove. At right, the assembly in perspective showing the offset panels.

EXEMPLARY ARCHITECTURAL APPLICATION

Color-rich and highly ornamented styles, such as Folk Victorian, benefit from the variety of shingle styles and colors offered by polypropylene and vinyl shapes.



Figure 16: Example of straight shake and scallop shingle.



Figure 17: Example of popular shingle pattern.

CLADDING PROFILES: SOFFIT

Soffit panels generally cover the underside of eaves or exterior planchements, including porch ceilings and the underside of cantilevers. Manufacturers make several patterns in vinyl, including vented soffits (every panel has vent holes), center vented (every other panel has vent holes), hidden vented (vent holes camouflaged in panel grooves), and non-vented soffits. Each vented type provides a different degree of air intake for the convection cooling of roof sheathing and attics. See manufacturer specification for ventilation area, especially when installed under narrow

eaves. Non-vented soffits come in the same patterns as the perforated variety, including a 3.5-inch chamfer style and a 2-inch beaded ceiling with an elegant, tooled ovolo between boards. Beaded soffits are also used for wainscoting and vertical siding applications. These panels run 16 feet in length, so they offer an opportunity to design a tall wall without seams. Several manufacturers offer soffit material with post-consumer recycled PVC. Soffit panels do not incorporate insulation.

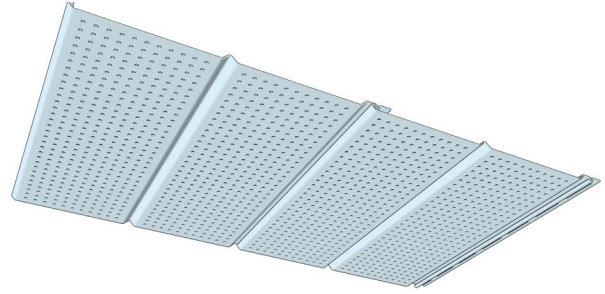
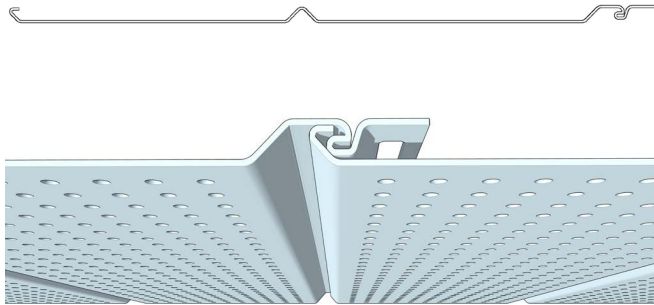

Figure 18 (i-18a, i-18b, i-18c): At top, a profile of vented soffit panels; above, a typical joint between two vented soffit panels; at right, a composite assembly of two panels.

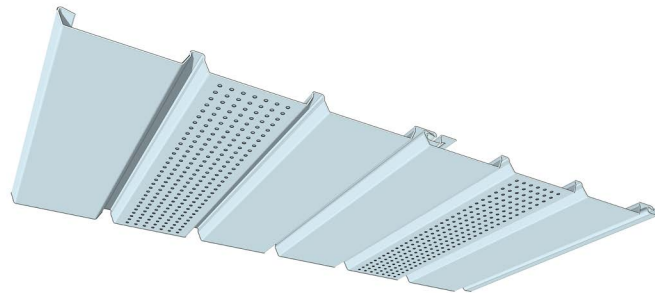
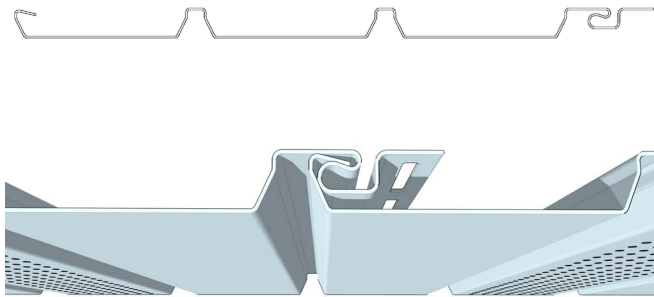

Figure 19 (i-19a, i-19b, i-19c): At top, a profile of center-vented soffit panels; above, a typical joint between two center-vented soffit panels; at right, a composite assembly of two panels.

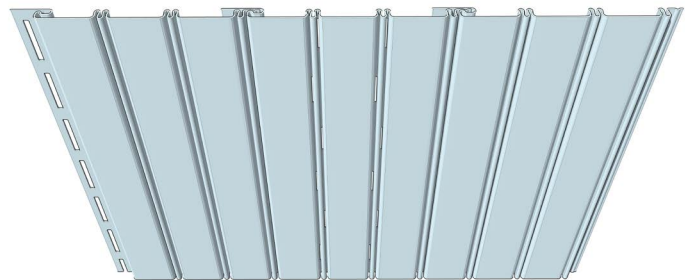
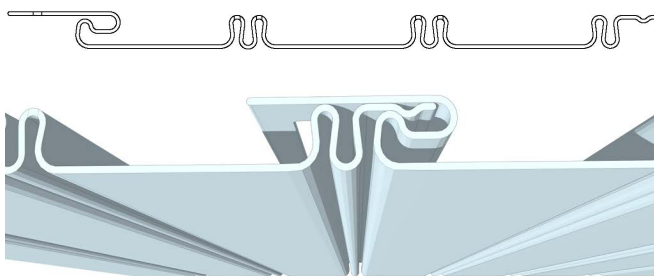

Figure 20 (i-20a, i-20b, i-20c): At top, a profile of hidden-vented soffit panels; above, a typical joint between two hidden-vented soffit panels; at right, a composite assembly of three panels with vent perforations in between panel beads.

CLADDING PROFILES: VERTICAL

BOARD-AND-BATTEN

Board-and-batten siding comes with narrow battens superimposed on wide boards, or the reverse pattern, with wide panels over narrow chamfers to mimic board-on-board siding (also known as chamfer or channel siding). Vinyl and cellular-PVC cladding mimic these patterns well. These vertical sidings offer an advantage at locations where seams would detract from the surface, because the vertical joints between panels remain invisible. Vertical siding easily

conforms to an arch, as it easily scribes around it. This style of siding also works its way around the curved surface (see Figure 25), where horizontal profiles would not. Since board-and-batten styles are constructed with rough-sawn lumber, all vertical siding styles come with a wood-grain texture. Nonetheless, architects have used this material to approximate the verticality of corrugated steel siding.

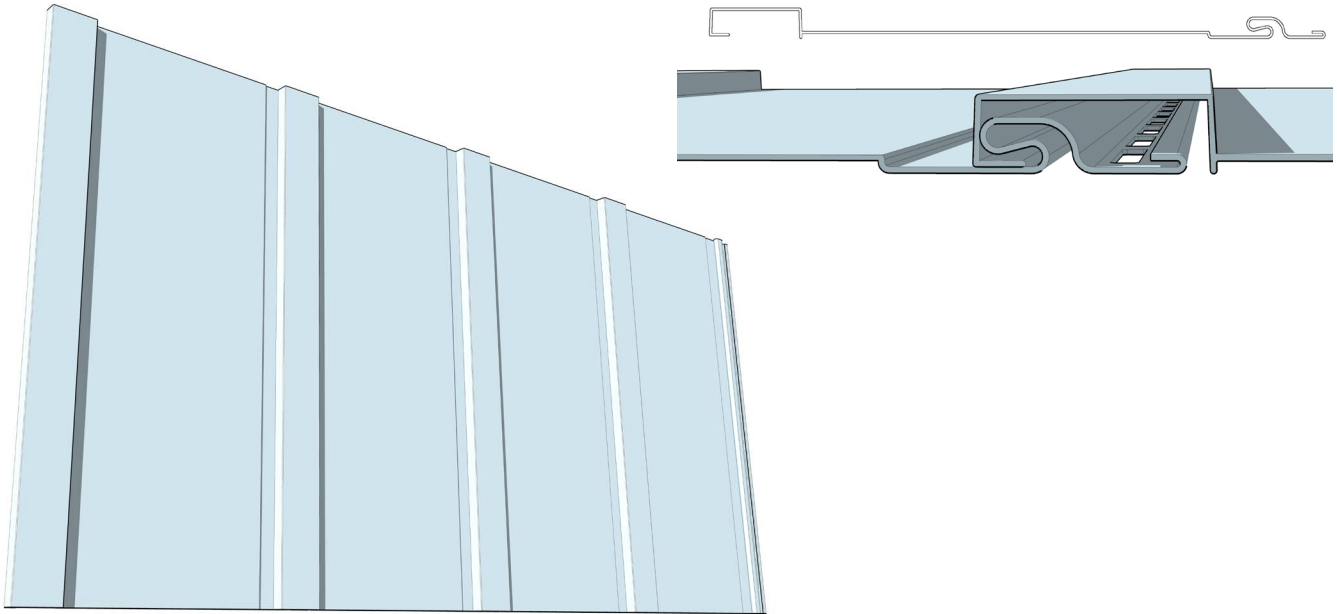

Figure 21 (i-21a, i-21b, i-21c): Above, a composite assembly of two board-and-batten panels; top right, a vinyl board-and-batten profile; below right, a typical joint between two board-and-batten vinyl panels.

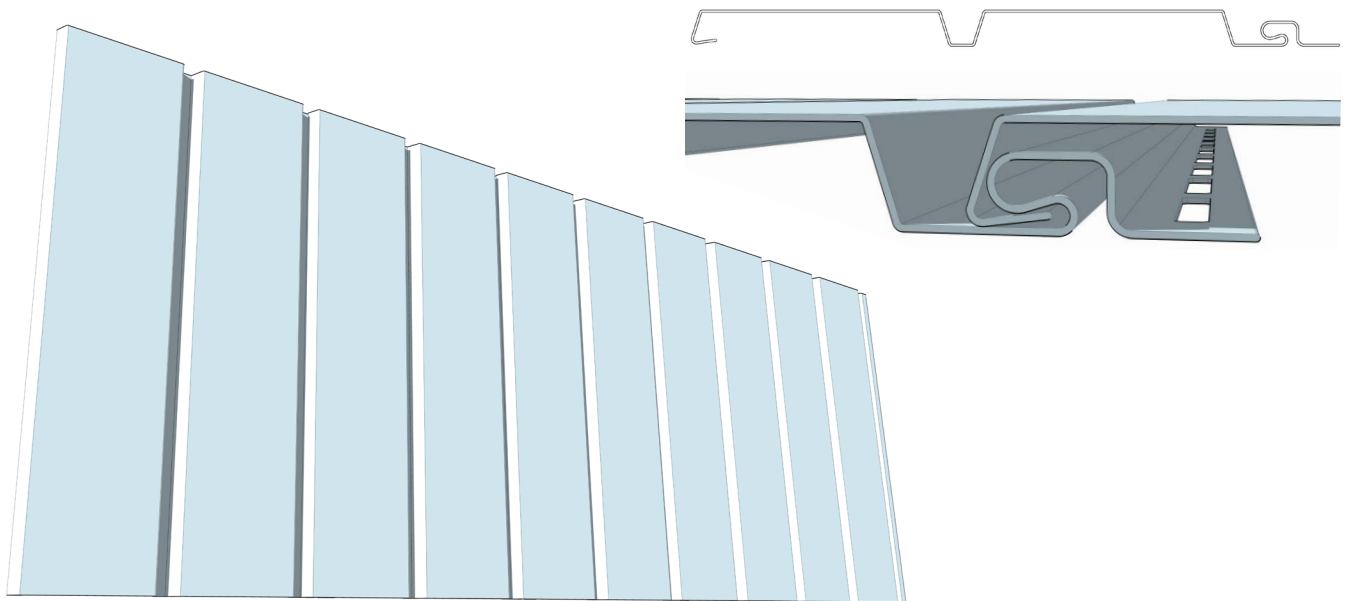

Figure 22 (i-22a, i-22b, i-22c): Above, a composite assembly of two board-on-board panels; top right, a board-on-board vinyl panel profile; below right, a typical joint between two board-on-board vinyl panels.

OTHER VERTICAL SIDING

Cellular PVC, polyurethane, and vinyl manufacturers offer various interior and exterior vertical siding panels with proprietary patterns, including V-groove and beaded single-

profile panels, 3/8 inch to 5/8 inch thick, much like wood boards. Sometimes these boards are sold precut and in kits for wainscot applications, including a base and top rail.

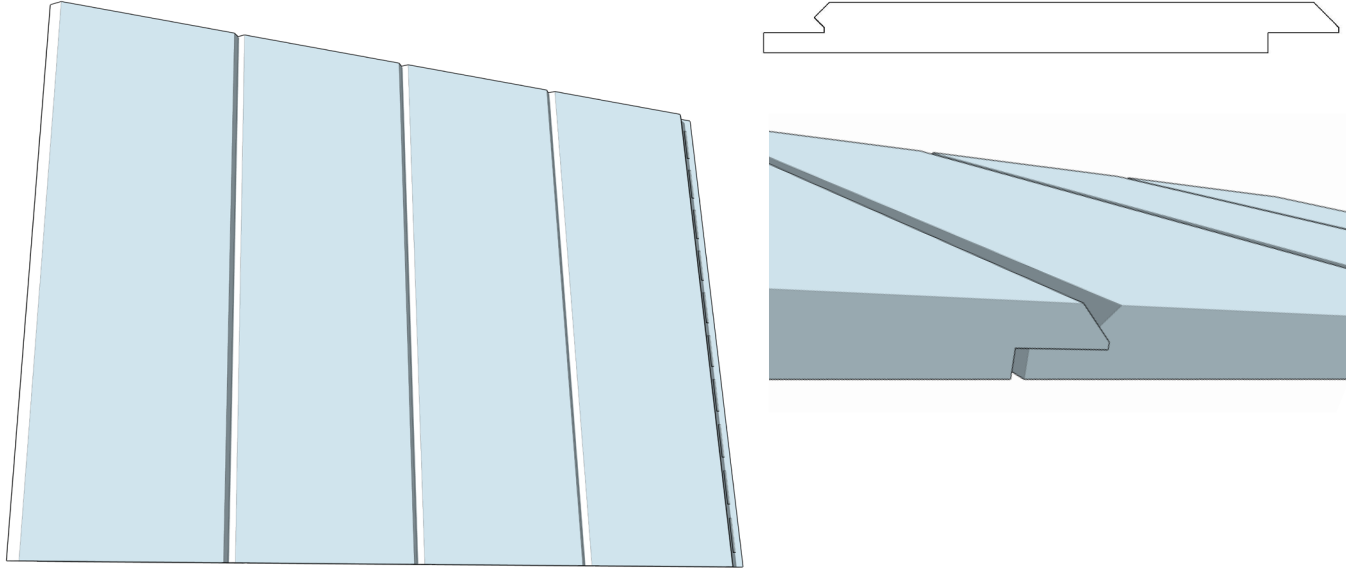

Figure 23 (i-23a, i-23b, i-23c): Above, a composite assembly of two wainscot panels; top right, a wainscot vinyl panel profile; below right, a typical joint between two extruded wainscot vinyl panels.

EXEMPLARY ARCHITECTURAL APPLICATION

Board-and-batten sidings represent a traditional material with a strikingly modern feel, as shown in the contemporary bungalow on the left. The image at right illustrates how vertical siding offers a practical solution when the architecture features a curved wall.



Figure 24: Modern example of board-and-batten.



Figure 25: Example below window of vertical siding around curve.

CLADDING PROFILES: OTHER MATERIALS

STONE/MASONRY

In recent years, manufacturers have created convincing facsimiles of stone. At arm's length, the appearance of this engineered polypropylene is difficult to distinguish from the natural materials. Sometimes called composite stone, this

lightweight material comes in various styles, including dry-stacked stone, ledgerstone, and river rock. Manufacturers offer assorted colors and sometimes incorporate mineral admixtures that provide a rugged and realistic texture.

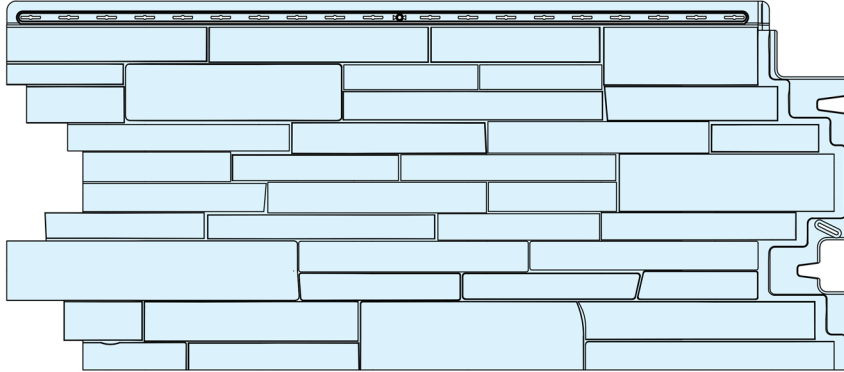

Figure 26 (i-26): Ledgerstone profile in polypropylene. Panels are generally 4 feet long and fit without visible seams. Most often, the nailing pattern is 8 inches on center.



Figure 27: Stacked stone samples on a residential structure. Although uncommon to use stone as a whole-house house cladding in traditional neighborhood applications, the material offers an accurate rustication for exposed foundations and decorative accents.

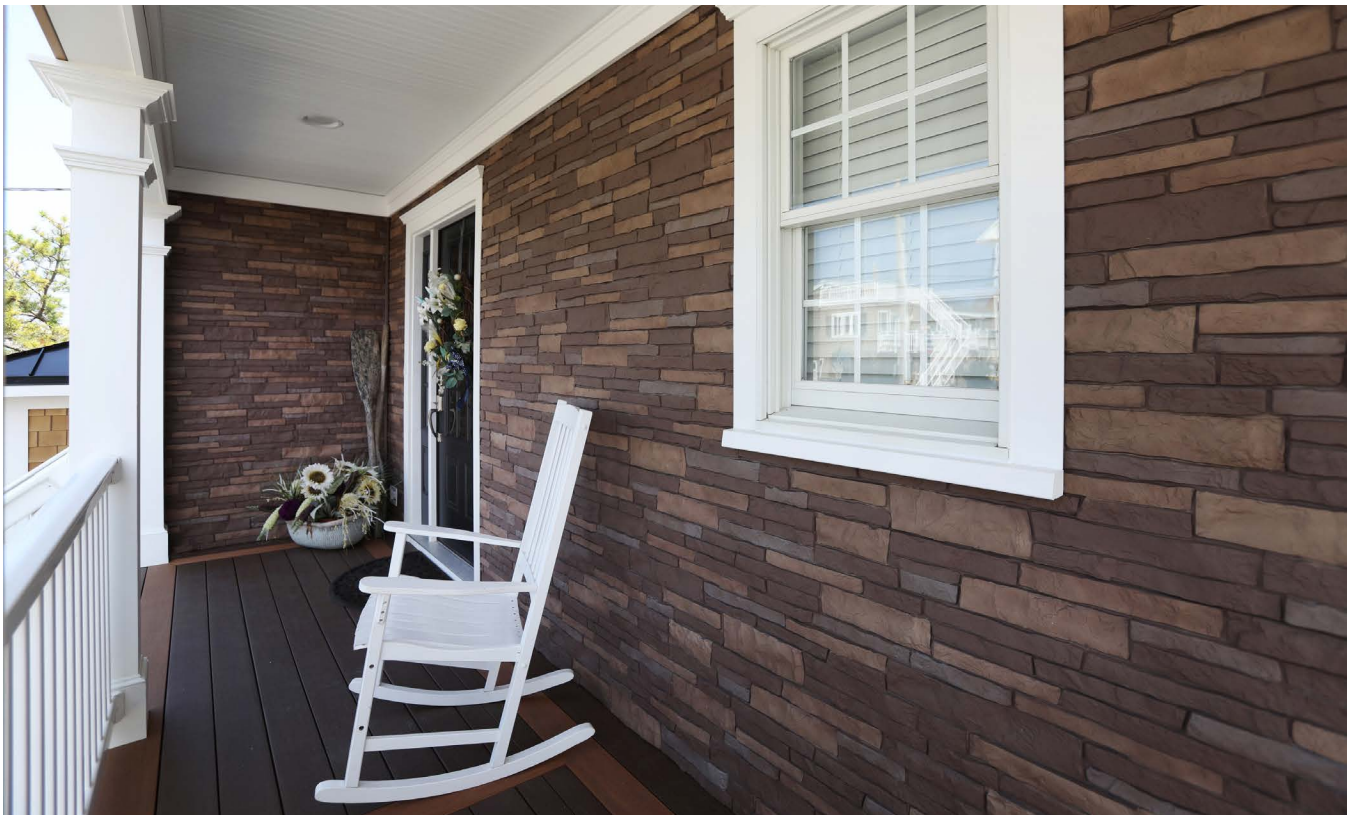

Figure 28: Manufacturers of faux masonry in polypropylene have developed authentic profiles and colors that offer a lightweight alternative to adhered masonry veneers at a fraction of the cost.

II. POLYMER TECHNOLOGY

VINYL SIDING

Vinyl is a colloquial name for polyvinyl chloride or PVC. Vinyl siding is made from extruded, unplasticized PVC with additives that enhance impact resistance, add color, and provide ultraviolet (UV) light protection and other performance enhancements. Vinyl siding is regulated under the International Residential Code and the International Building Code. The material is recyclable, and manufacturers

may include both post-industrial and post-consumer recycled content in their material's substrate or structural layer. Some colors offer cool-wall reflectance. Manufacturers are developing cool-wall-rated products in collaboration with the CCRC's Wall Rating Program, which is anticipated to launch in 2022. The International Residential Code and International Building Code regulate vinyl siding and soffits.

INSULATED VINYL SIDING

Insulated vinyl siding is vinyl siding with a backing of solid, rigid-foam insulation. The International Residential Code and International Energy Conservation Code regulate insulated vinyl siding, providing a minimum R2.0. Some profiles offer insulation from R3 to R5. The insulation makes the siding stiffer and highly resistant to impacts by filling the voids behind the siding's stepped profile. Some profiles are wide and flat, without the concave appearance of traditional vinyl clapboard. The insulating foam comes laminated to the vinyl siding, providing lifelong adhesion. Insulated siding maintains the characteristics of a vented cladding, including breathability, vapor permeability, and bulk moisture management properties. As continuous exterior insulation, it also contributes to water vapor management per the 2021 IRC.

Figure 29: The image at right depicts a section of insulated vinyl siding showing the contoured and laminated rigid foam insulation. As continuous exterior insulation, this cladding contributes to the thermal performance of the wall. Note the flat face of the wide-plank profile.



POLYPROPYLENE SIDING

Unlike vinyl siding, which is extruded, polypropylene siding is injection-molded plastic. This technology allows manufacturers to cast molds upon the materials they reproduce, obtaining an accurate dimension and texture. Polypropylene is regulated in the International Residential Code and International Building Code. The typical

application for this kind of siding is shake and shingle cladding with a cedar pattern, which can be used as a whole-house cladding or in accent areas. Most masonry and innovative metallic-looking shingles are also molded with polypropylene.

SOLID CELLULAR PVC SIDING

Cellular PVC refers to a type of air-entrained polyvinyl chloride that can be shaped and molded, much like milled wood. Cellular PVC siding is more expensive than standard vinyl siding but offers crisp corners, a solid feel, and high impact resistance. The building codes do not regulate cellular PVC cladding, but manufacturers provide third-party Code Compliance Research Reports by accredited laboratories.

Figure 30: Example of solid cellular PVC siding.



SOLID CELLULAR PVC TRIM/ORNAMENTS

As a highly workable material, cellular PVC provides an exceptionally wide range of molding and architectural ornaments, from casing to brackets and column capitals to full entablatures. Anything available in a wood millwork catalog is available in cellular PVC.

Figure 31: Cellular PVC corbels come in various sizes, from small, ornamental filigree to substantial eaves brackets, as depicted in the photo at right.



OTHER POLYMERIC INNOVATIONS

Polyurethane and polyash sidings have come into the market as an alternative to the toxicity of fiber cement. Unlike PVC, these materials do not have a high thermal expansion rate, allowing butt joints and requiring no pocketed or J-channels. The material is solid and can be tooled like wood. Since the material incorporates glass fiber rather than wood, it will not wick moisture or suffer freeze/thaw issues. It can remain in

ground contact or run along the roof rake without an air gap. Although not regulated by the building codes, polyash is approved for Urban Wildland Interface installations as a fire-resistant material. Manufacturers provide third-party Code Compliance Research Reports by accredited laboratories.

III. COLOR

Polymeric claddings come in a broad and ever-increasing spectrum of colors, including traditional pastels and earth tones as well as darker color options featuring barn reds, hunter greens, deep blues, and more. Many offer lifetime color warranties, even for darker hues. Factory-colored and

paintable products are available in both cladding and trim. Colors are tested and manufacturers offer warranties that will guarantee the color will perform for the product's life in many cases.

IV. TEXTURE

Vinyl and other polymeric siding profiles are available in varying textures, from deep wood grain to smooth, that replicate sanded, sealed, and painted wood. Specialty profiles, like shakes and shingles, are also available in a variety of textures to simulate authentic wood grains. You will see names like hand split, rough split, and rough sawn, among others. This assortment of textures makes vinyl and other polymeric siding suitable for a wide range of architectural styles. For instance, smooth or sanded wood-grain textures are ideal to showcase on the monolithic

exteriors of Greek Revival, Italianate, or Georgian houses. Textured shingles, shakes, or other shapes can contribute significantly to the eclectic patterns that embellish Queen Anne and Folk Victorian gables and façades. The rugged textures that simulate rough-hewn cedar shakes can enhance the rustic look of Cape Cod or Craftsman styles. Best of all, low-maintenance vinyl and other polymeric siding can re-create the various looks of wood without the worries of rotting, swelling, warping, chipping, peeling, fading, or insect infestation.



Figures 32-34: From left to right: deep wood-grained texture, painted brushstroke texture, and smooth texture.

Chapter 2

Trim

IN THIS CHAPTER

Trim functions as both a decorative and functional element. In this chapter we focus on the important trims for polymeric cladding performance. These elements maintain the drainage plane that allow vinyl siding to function as a rainscreen cladding. The pocketed trims permit the natural thermal movement characteristic of polymeric materials. Other trims ensure that vinyl siding will remain on the wall even during high wind events. To enhance the application, manufacturers have coupled functional trim with decorative elements, such as pocketed casings and head trims, and ornamental cornices that also act to secure siding at the top of the wall. In summary, proper use of trim will prevent blow-off and allow for a continuous drainage plane. When certain trims, such as J-channel, create an undesirable visual condition, integrated pocket edges and composite architectural details can act as camouflage. In the case of insulated siding, the application of compatible trim will ensure a continuous exterior thermal break approved by the IRC and IECC. For more information on concealing objectionable connections, refer to Chapter 4 Workarounds.

I. FUNCTIONAL TRIM

- STARTER STRIP
- UTILITY TRIM
- J-CHANNEL
- POCKET TRIM

II. HEAD TRIM

III. VERTICAL CASING

IV. WINDOWSILLS

V. CORNERS (INSIDE/OUTSIDE)

VI. HORIZONTAL BANDS

VII. CORNICE (TOP-OF-WALL TRIM)

VIII. FASCIA

IX. SPECIALTY TRIM

- CELLULAR PVC TRIM
- CLASSICAL TRIM

I. FUNCTIONAL TRIM

STARTER STRIP

Starter strip serves to hold the first course of horizontal siding level and firmly to the wall. It also provides a weep-screed that drains moisture from behind the siding. A starter strip is required at the first course of a new section of

siding, even when transitioning over a belly band. Vertical siding and polypropylene shapes may not require a starter strip and install over J-channel instead. Always refer to the manufacturer's recommendations.

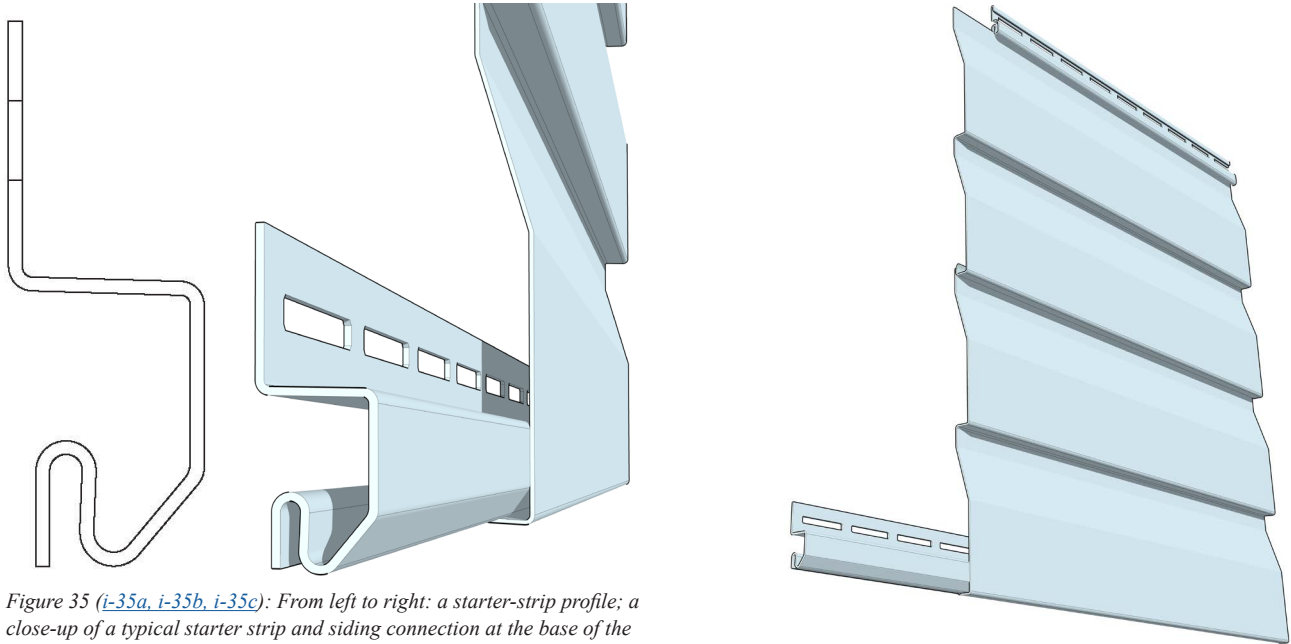

Figure 35 (i-35a, i-35b, i-35c): From left to right: a starter-strip profile; a close-up of a typical starter strip and siding connection at the base of the wall; and the composite assembly.

UTILITY TRIM

Utility trim must install with snap-lock punch tabs under windows, where the siding is cut to scribe the opening, and at the top of the wall, where the siding's last panel meets the soffit. Omitting utility trim and snap-lock punch tabs at these locations will result in panel blow-off. When the panel cut occurs where the profile is too far from the wall for a utility trim, use an "F" utility trim to avoid deforming the panel.

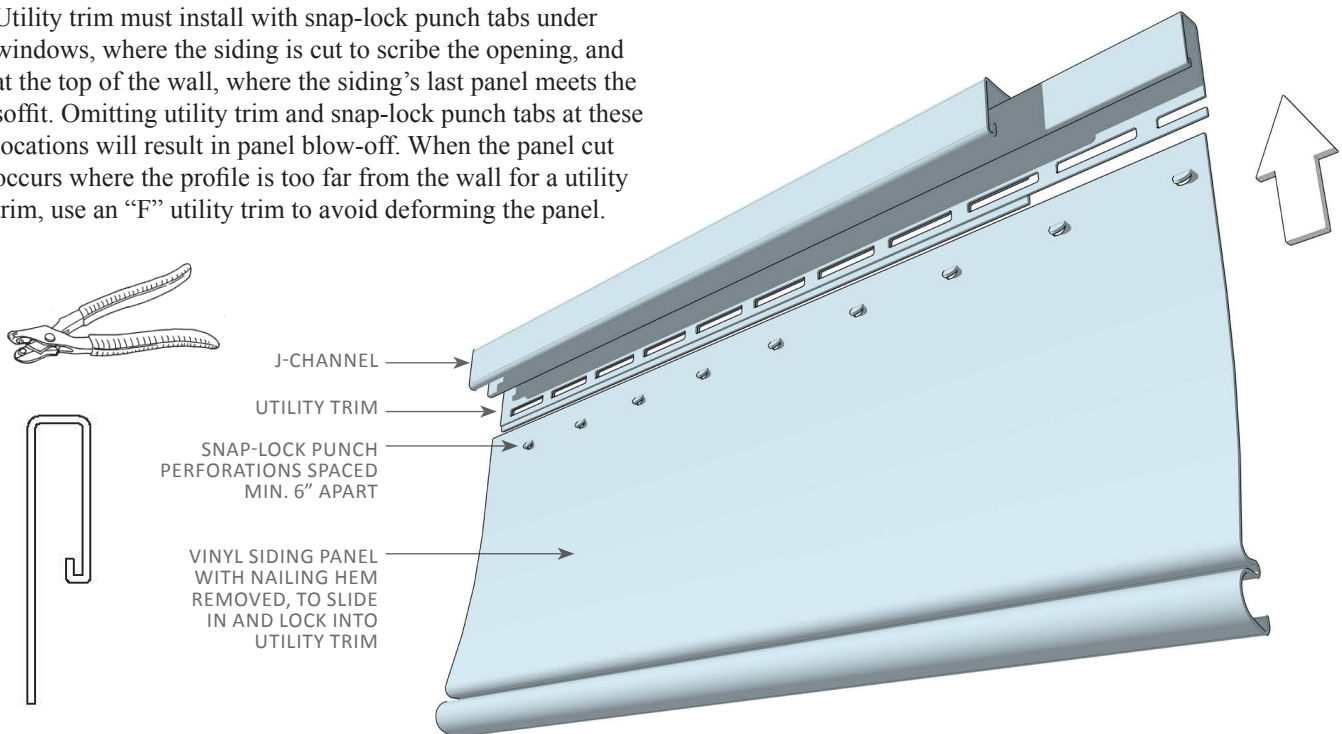

Figure 36 (i-36a, i-36b, i-36c): Top left, a snap-lock punch tool; above left, utility-trim profile; right, the assembly with J-channel, utility trim, and vinyl siding panel with nailing hem removed and snap-lock punch perforations spaced minimum 6 inches apart.

J-CHANNEL

J-channel is basic, functional pocket trim with excellent moisture performance that permits thermal expansion of siding panels. This trim has had limited architectural acceptance as a material-specific trim that adds a 1-inch reveal and shadow line overlapping the siding panels. See Chapter 4 Workarounds for alternatives.

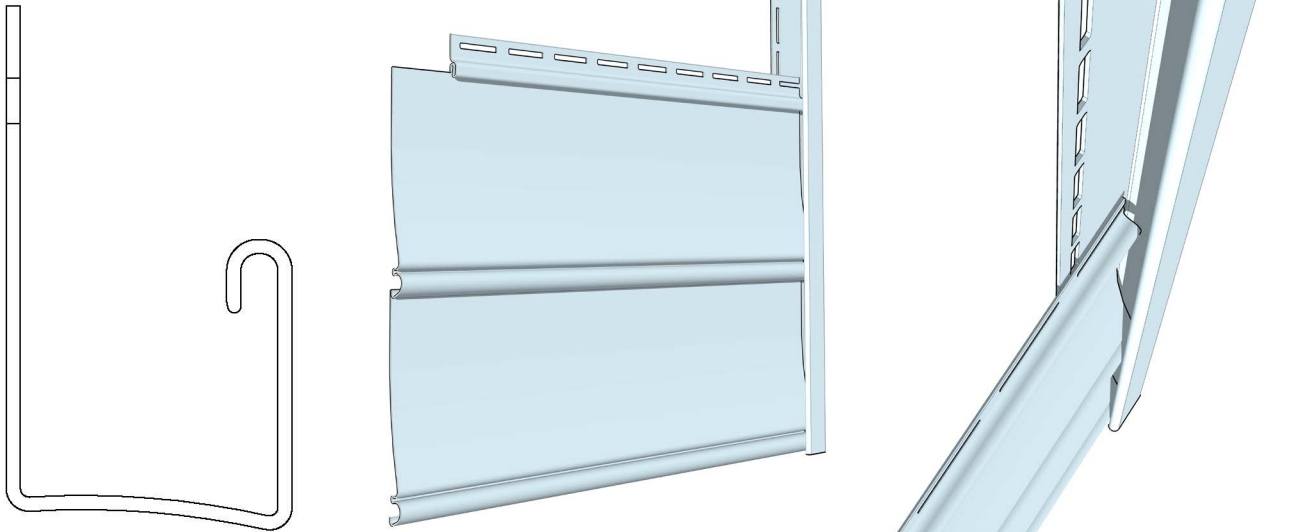

Figure 37 (i-37a, i-37b, i-37c): From left to right: a J-channel profile; the facade of a horizontal beaded single siding terminated within a J-channel; and looking down to the joint to show the profile of the J-channel.

POCKET TRIM

Pocket trim is an alternative to J-channel that preserves the complete moisture management system and provides an area for material expansion and contraction. As vented claddings, vinyl siding and polypropylene sidings are considered

rainscreen systems. To safeguard the system's moisture and vapor management advantages, use conventional J-channel, pocketed moldings, or built-up pockets if correctly detailed.

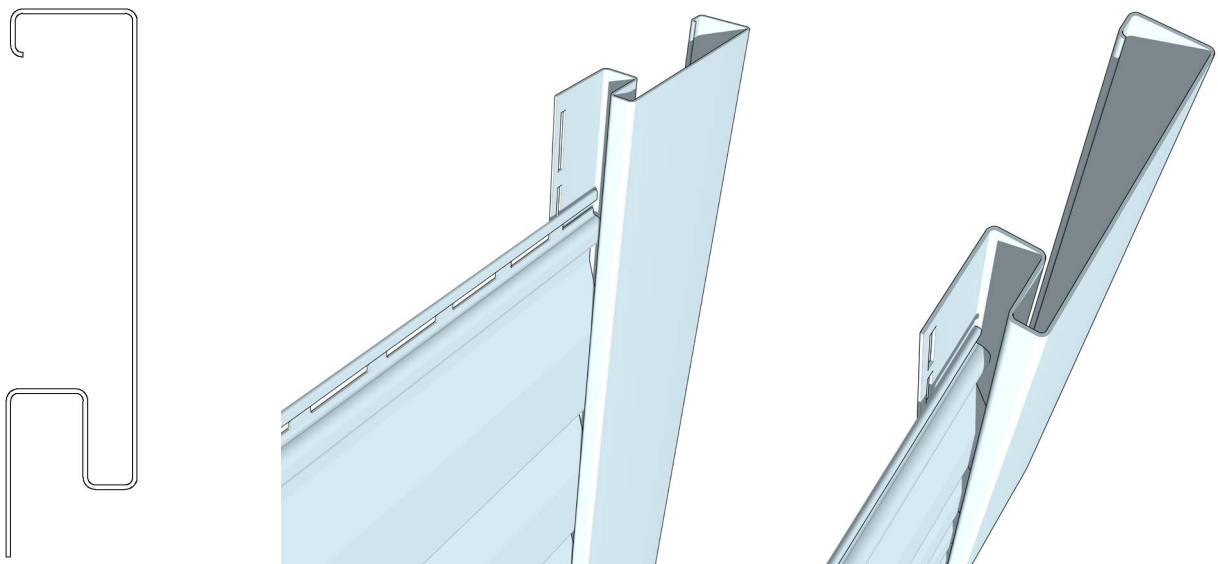

Figure 38 (i-38a, i-38b, i-38c): From left to right: a section of pocketed lineal trim; the facade of a horizontal Dutch lap double siding terminated within a pocket trim; and the same corner in closer detail, looking down at the joint to show how the pocket trim receives the siding profile.

II. HEAD TRIM

Depending on the architectural style, windows and doors may use a plain head trim or something more elaborate, such as a pediment with a crown. These ornamental patterns are available in both vinyl and solid cellular profiles.



Figure 39 (i-39): Flat window head trim.

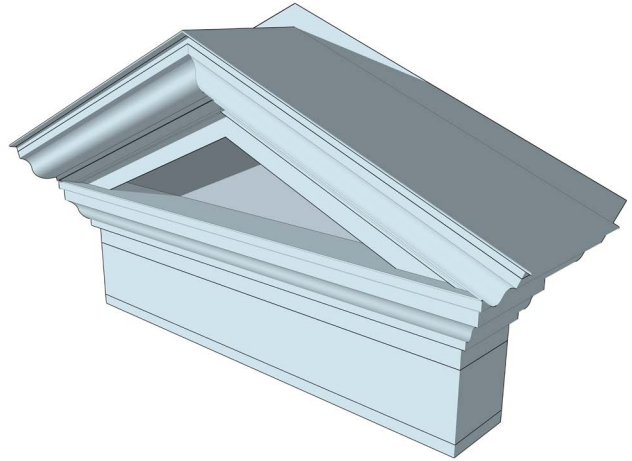
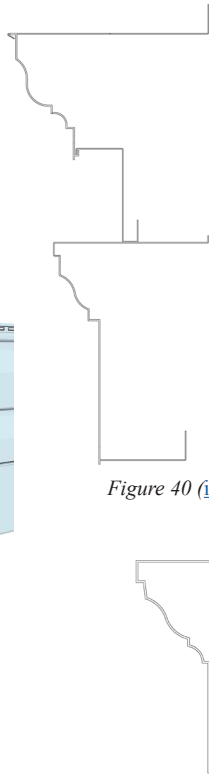

Figure 40 (i-40a, i-40b): At left, a pediment profile; at right, the pediment in perspective.

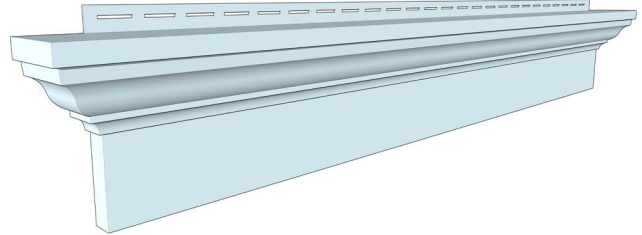

Figure 41 (i-41a, i-41b): At left, a crown profile; at right, the crown in perspective.

EXEMPLARY ARCHITECTURAL APPLICATION

Built adjacent to Kentlands, the Lakelands neighborhood in Gaithersburg, MD, by New Urbanist Andrés Duany, shows the variety of color and ornamentation available with polymeric cladding and trims. This variety works especially well on Federal-style row houses.



Figures 42 & 43: Exemplary application of window and trim packages at the Lakelands Neighborhood, Gaithersburg, MD, by DPZ CoDesign.

III. VERTICAL CASING

Known as “lineals,” vertical casing profiles offer a range of board widths from 3 inches to 10 inches with a built-in pocket or J-channel on one edge. When using insulated siding, these trims come with foam backing to provide continuous exterior insulation.

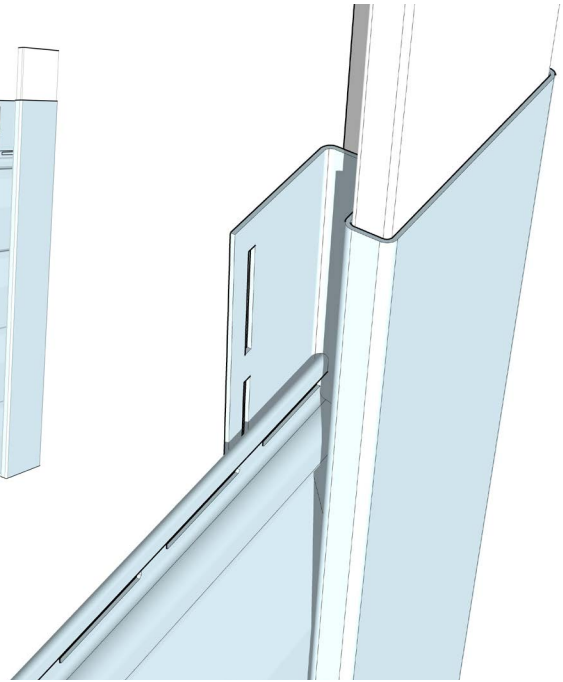
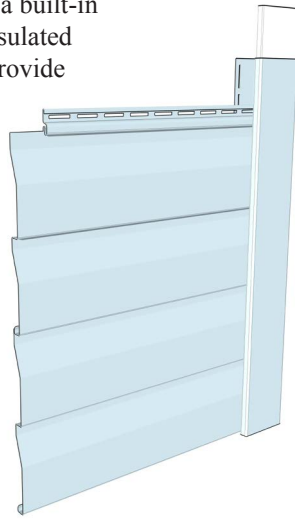
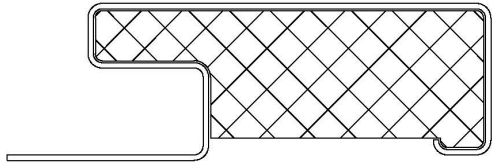

Figure 44 (i-44a, i-44b, I-44c): From left to right: a window casing profile with insulation; a Dutch lap siding facade terminated within a vertical window casing with insulation; and a close-up of a vertical window casing with insulation.

IV. WINDOWSILLS

Windowsill profiles in vinyl and cellular PVC provide a traditional window appearance without adding unreasonable expense.

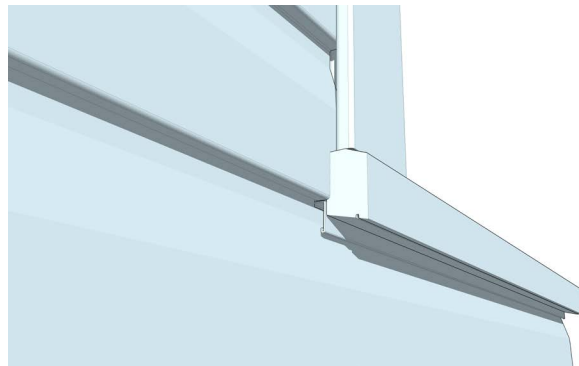
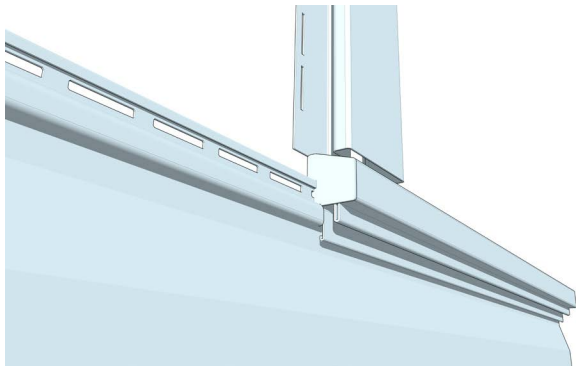
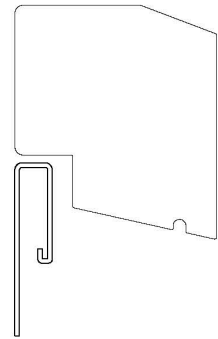
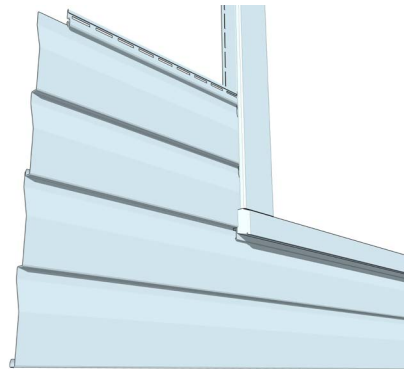
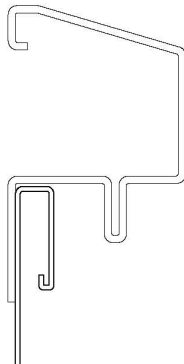
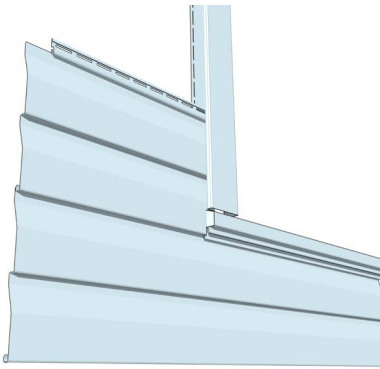

Figure 45 (i-45a, i-45b, i-45c): Vinyl windowsills with utility trim included.

Figure 46 (i-46a, i-46b, i-46c): Cellular PVC windowsills.

V. CORNERS (INSIDE/OUTSIDE)

Inside corner trims are generally 1 inch wide while outside corners range from 3 inches to 6 inches. Many include embellishments, such as flutes, chamfered, or oval profiles.

Some offer clip-on color trims to accent quarter-rounds at the apex. For wider inside corners, installers can use a vertically placed lineal.

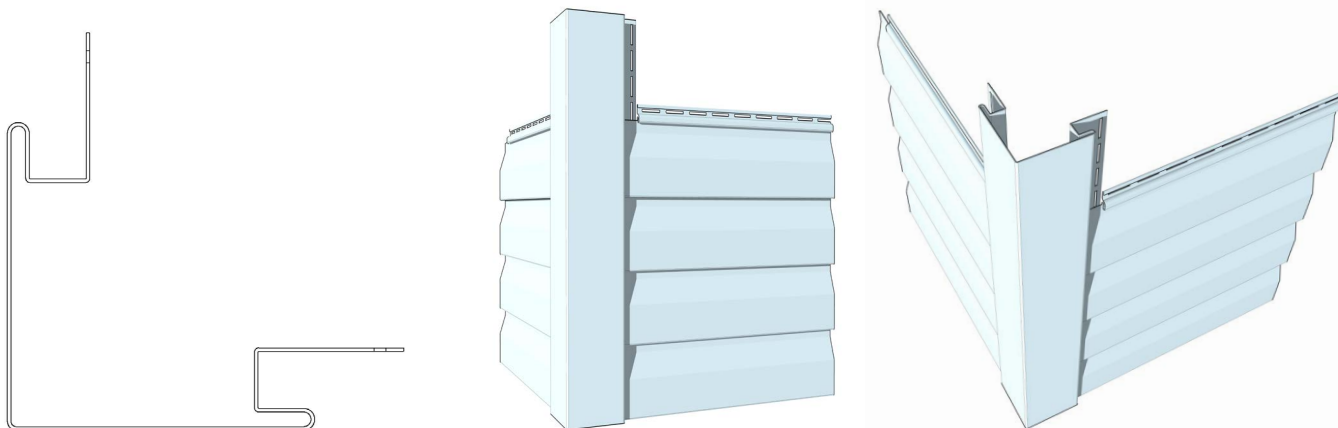

Figure 47 (i-47a, i-47b, i-47c): Smooth corner trim with horizontal Dutch lap siding.

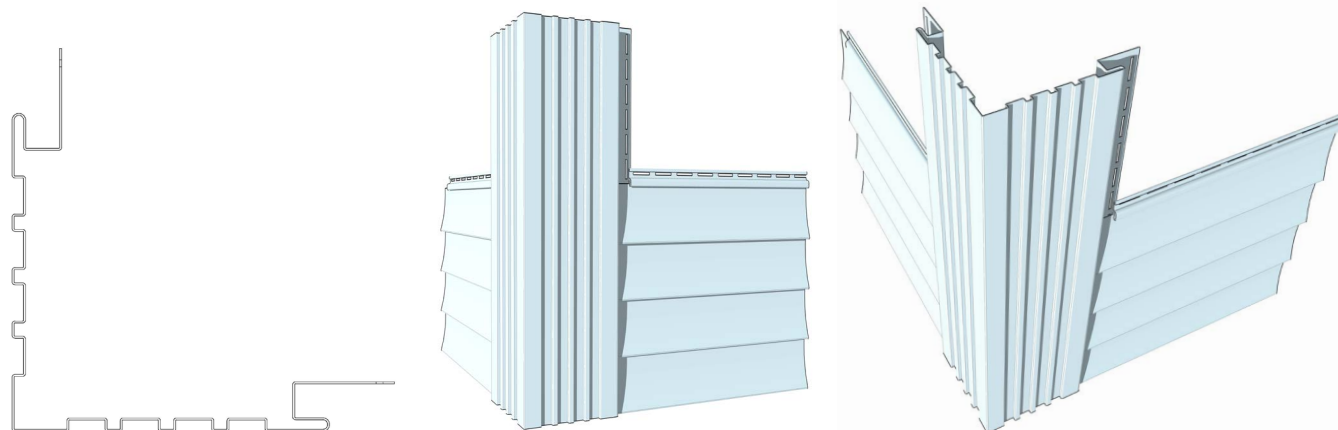

Figure 48 (i-48a, i-48b, i-48c): Fluted corner trim with horizontal clapboard siding.

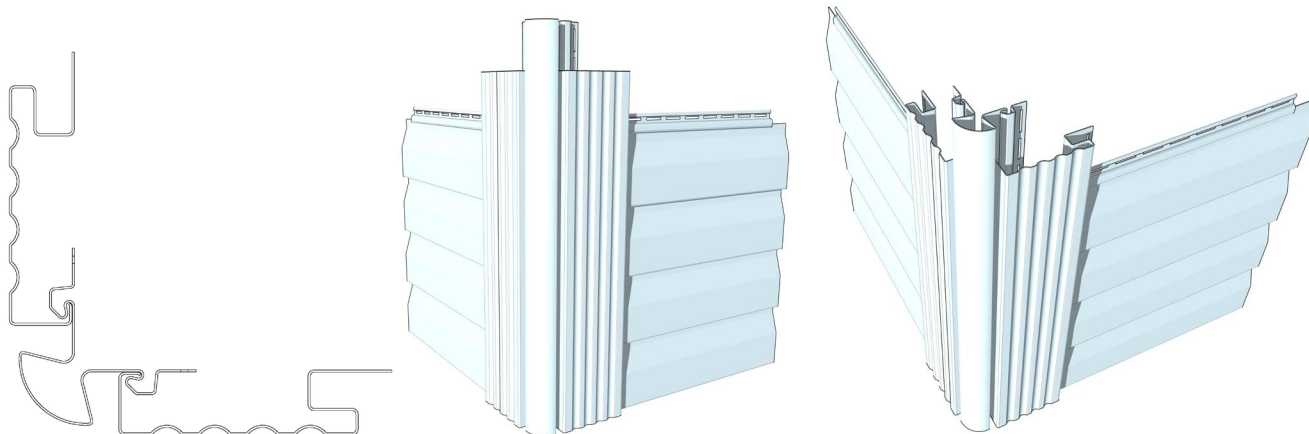

Figure 49 (i-49a, i-49b, i-49c): Beaded corner starter trim with two fluted trims on a wall finished with horizontal Dutch lap siding.

VI. HORIZONTAL BANDS

Mid-band trims are used when transitioning profiles between stories or, in some cases, vertically between architectural features or changes in patterns. Mid-band trims come in a variety of colors and with or without foam insulation.

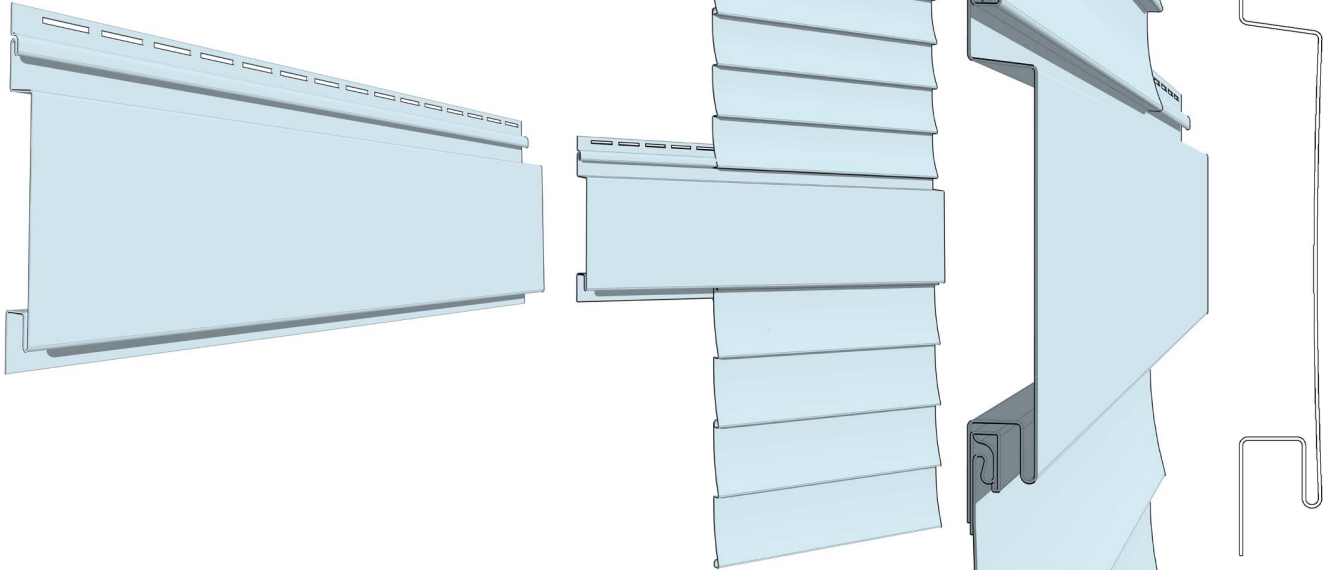

Figure 50 (i-50a, i-50b, i-50c, i-50d): From left to right: front view of a single horizontal band; the facade of a horizontal clapboard with a mid-band border; the joint between the horizontal band and siding; and a section of horizontal trim.

EXEMPLARY ARCHITECTURAL APPLICATION

The Italianate home on the left shows a horizontal band below the eaves to set off the decorative brackets along the soffit. Architect Andrés Duany uses a vinyl, horizontal

bellyband to separate the Palladian arches in the fourth story on the building on the right. Note the wide band that represents an architrave below the eaves.



Figure 51: Italianate house in Lincoln, NE, with vinyl clapboard siding and vinyl band below eaves.



Figure 52: Apartments at Lakelands, Gaithersburg, MD, by DPZ CoDesign with vinyl clapboard siding, vented vinyl soffits, and cellular PVC trims, columns, and embellishments.

VII. CORNICE (TOP-OF-WALL TRIM)

Top-of-wall trim is available in several forms, square (frieze board) or ornate, depending on the architecture. This functional trim comes in two parts: a receiver nailed to the

wall and a finish that clips onto it. This trim hides the cut in the last panel of siding and covers the utility trim.

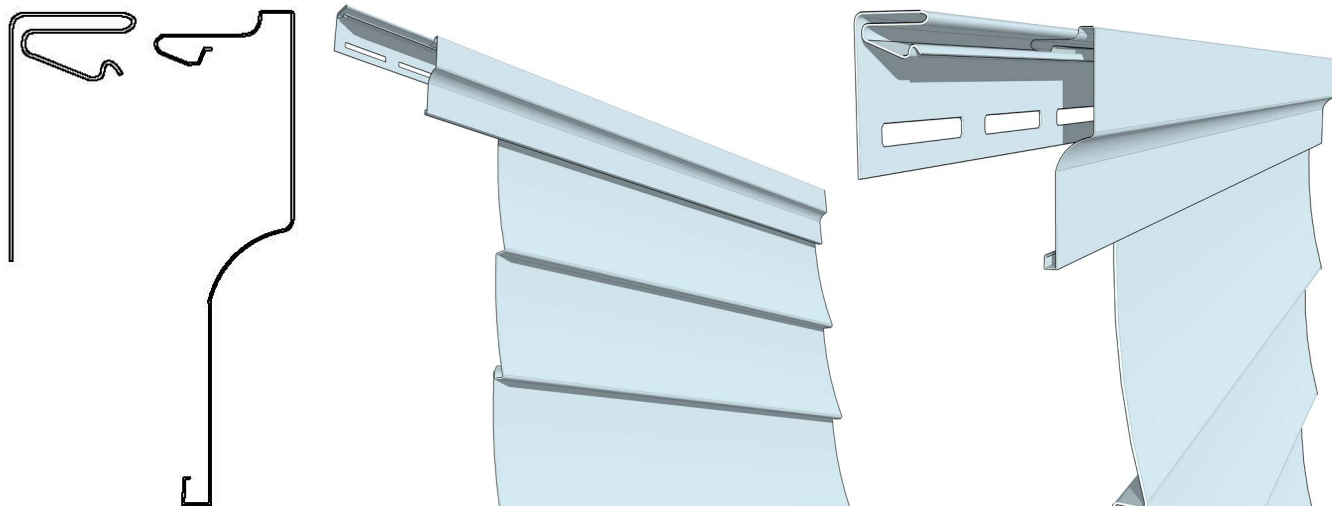

Figure 53 (i-53a, i-53b, i-53c): From left to right: a congé style top-of-wall trim profile; congé style top-of-wall trim in perspective/section; and top-of-wall trim in closer detail.

VIII. FASCIA

With vinyl soffits, the fascia cover is either aluminum or vinyl. Both come in a variety of colors. When using vinyl fascia, the top of the material slips into utility trim.

Aluminum fascia may also use utility trim but more commonly friction-fits under the roofing drip edge or gutter flashing.

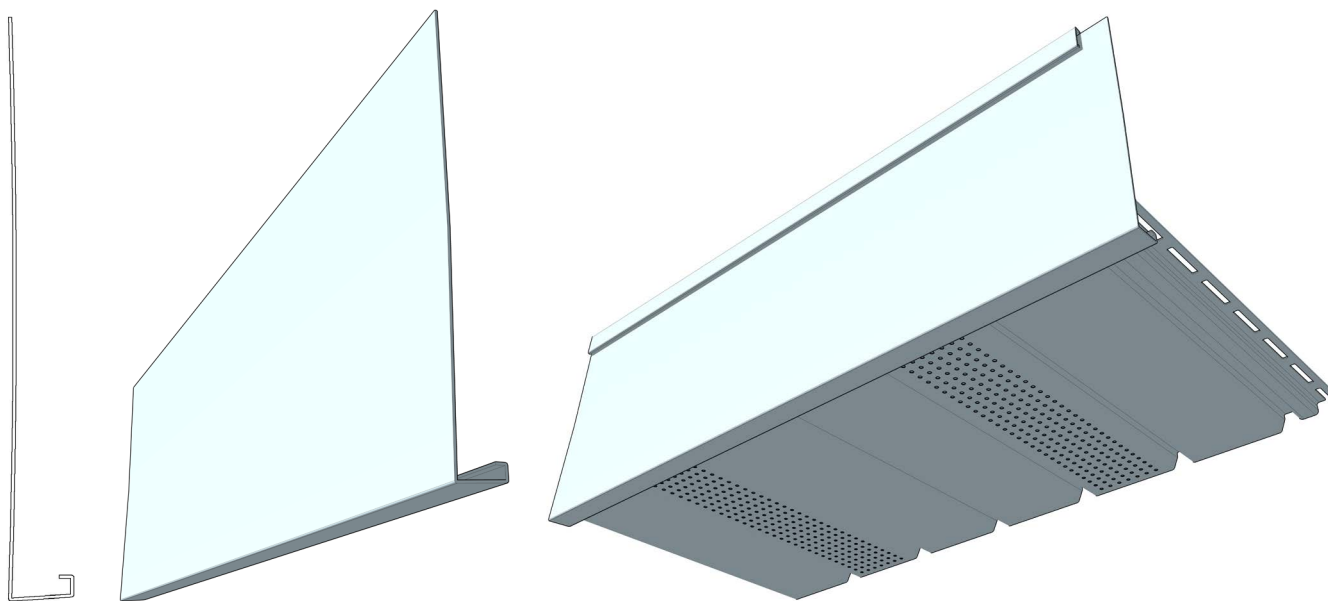

Figure 54 (i-54a, i-54b, i-54c): From left to right: a single fascia cover profile; a close-up of the fascia cover; and the fascia cover with center-vented soffit from below.

IX. SPECIALTY TRIM

CELLULAR PVC TRIM

Cellular PVC trim represents a category of solid, PVC material trim that most closely replicates wood trim but still utilizes a rabbeted profile for moisture management and thermal performance. These trims come in a wide variety of sizes and lengths. The material is readily assembled on-site.

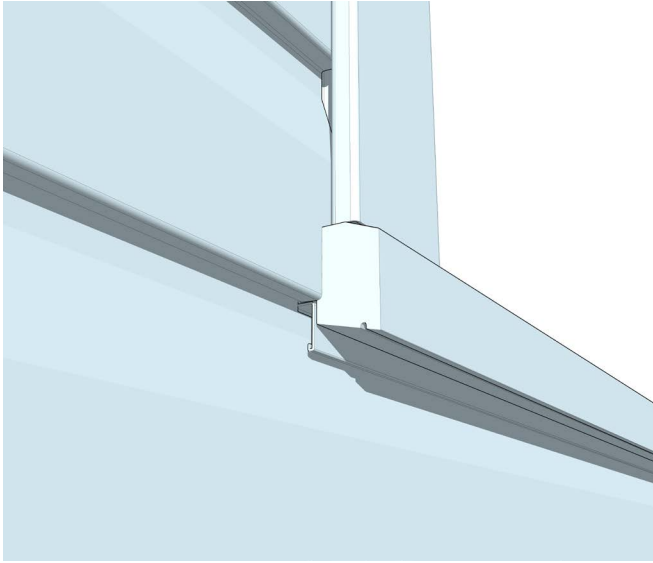
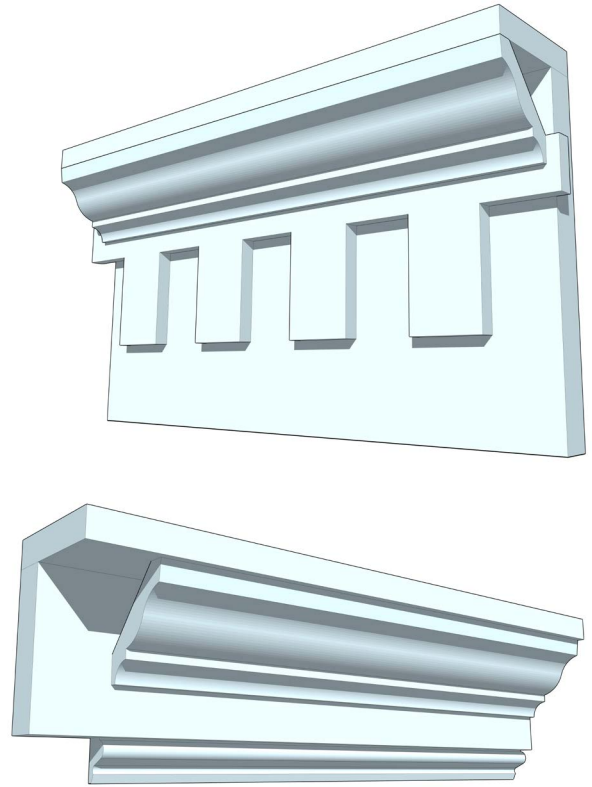

Figure 55: Some examples of cellular PVC trim include this windowsill (left [i-46c](#)), a dentil (top right [i-63](#)), and an entablature (bottom right [i-66a](#)).



CLASSICAL TRIM

Manufacturers offer complete window and door kits to reproduce traditional opening trims. These units adjust to the opening width and height.

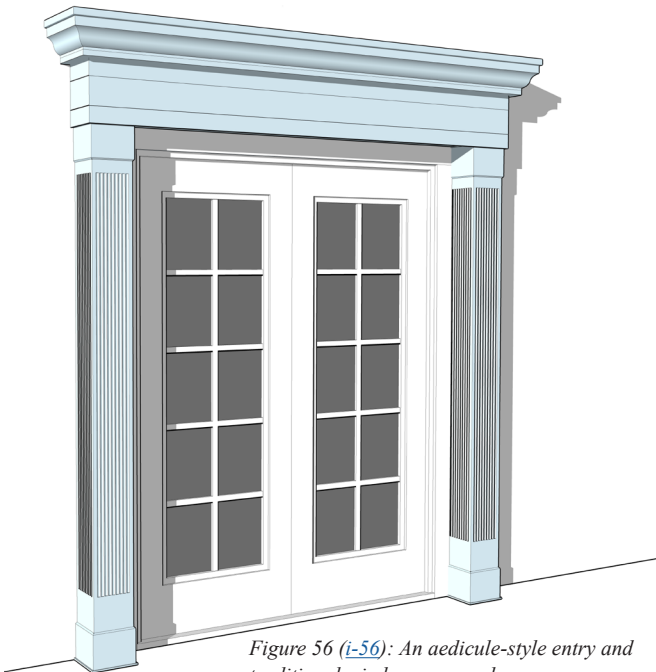

Figure 56 ([i-56](#)): An aedicule-style entry and traditional window surround.



Figure 57: Aedicule at Lantern Hill, Doylestown, PA, a vinyl-clad New Urbanist neighborhood by Carter van Dyke Associates.

Chapter 3

Ornaments

IN THIS CHAPTER

Ornaments serve as building embellishments without a functional role. Many of these mimic structural elements, such as eaves brackets, and should appear as strong physical supports, even if they are not. Here, plastic can reproduce the appearance of both large and small ornamentation. Consider the sizable classical columns available in cellular PVC, as well as the delicate Victorian gingerbread. Ornaments define a building style and can serve to articulate buildings, organizing the structure into a series of visual units. In traditional American architecture these dynamic elements come with vertical posts, horizontal bands, and punctuation, such as corner rosettes and center keystones. The full scope of decorative elements available for polymeric cladding, especially with cellular PVC, rivals any millwork catalog. This variety makes it possible for the designer to produce both authentic, period structures and highly inventive stylings. Since the selection outspreads the scope of this guide, designers may search online for available products.

- I. BRACKETS
- II. ROSETTES
- III. DENTILS
- IV. COMPOSITE CROWN
- V. KEYSTONES
- VI. PEDIMENTS
- VII. COLUMNS AND POSTS

I. BRACKETS

Cellular PVC and polyurethane brackets come in many sizes and styles, some large enough for buildings of significant scale. Although solid in appearance, these brackets are often hollow and attach to blocking affixed to the structure's

body. Since third-party manufacturers also fabricate these ornamental elements, a designer can search for the most appropriate or original complement.

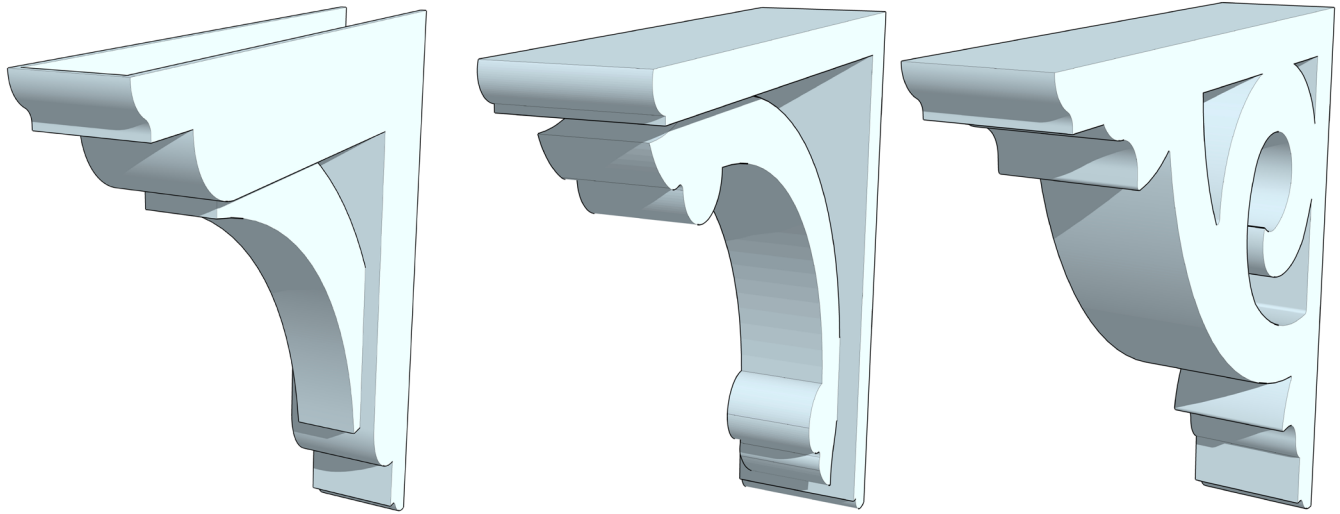

Figure 58 (i-58a, i-58b, i-58c): At left, vinyl bracket; center and at right, cellular PVC brackets with increasing level of detail.

II. ROSETTES

Rosettes, symbolizing the bowls from which ancient Greeks took their wine, come in vinyl siding and cellular PVC trims. The vinyl trims (shown) fit perfectly into the vinyl door and window lineals, preserving a drainage plane.

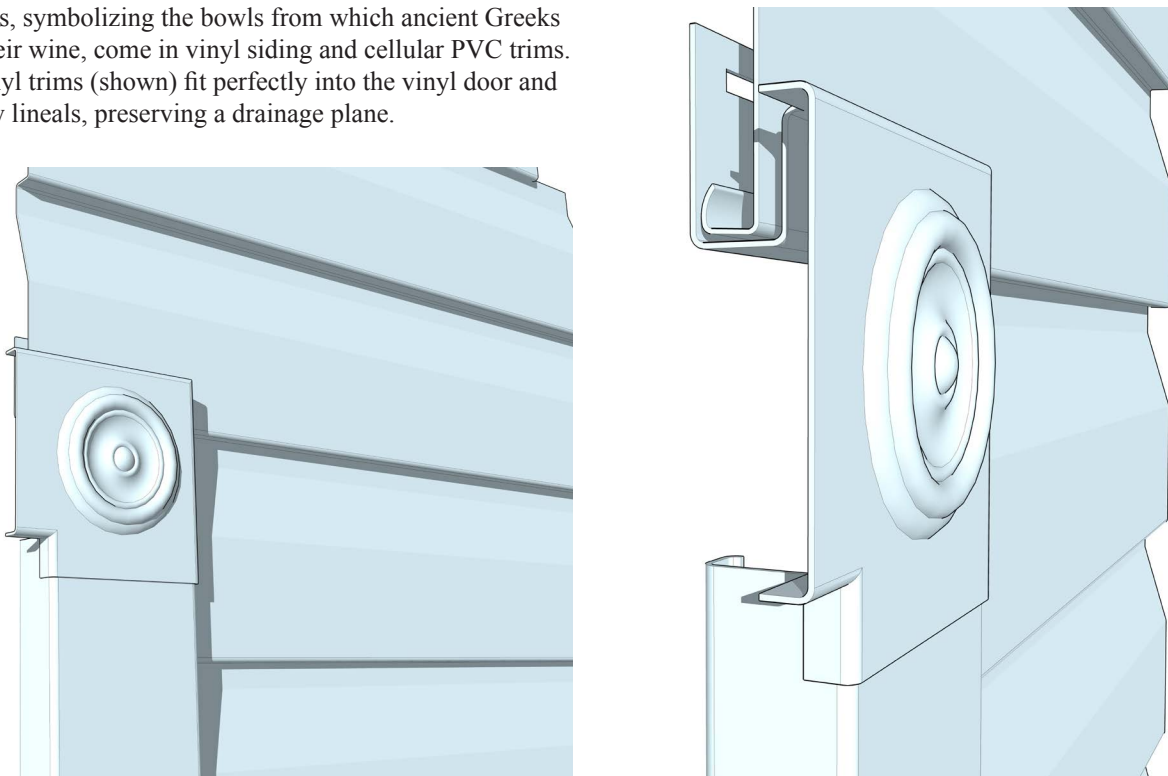

Figure 59 (i-59a, i-59b): At left, a rosette; at right, a close-up of the joint between a rosette and a lineal.

III. DENTILS

Dentils come in vinyl and polyurethane materials. They represent a wide range of decorative styles, from classical to Victorian. Sizes vary, from small enough to decorate a window pediment to large enough for a commercial building. Dentil molding and modillions are available in a wide range of sizes for both massive and delicate ornamentation.

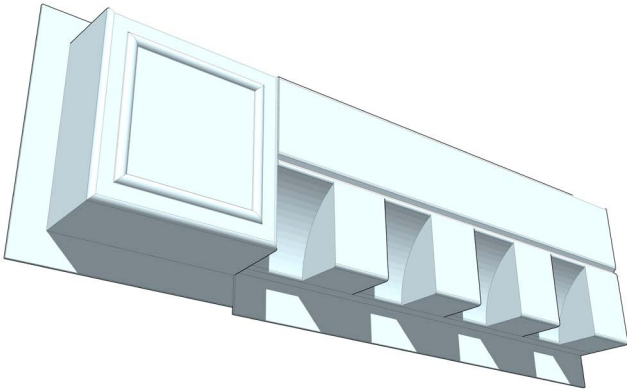

Figure 60 (i-60): A vinyl dentil crown molding with dentil molding end block.

Large and widely spaced dentils can function as decorative block modillions. Individual pieces are available in polyurethane.

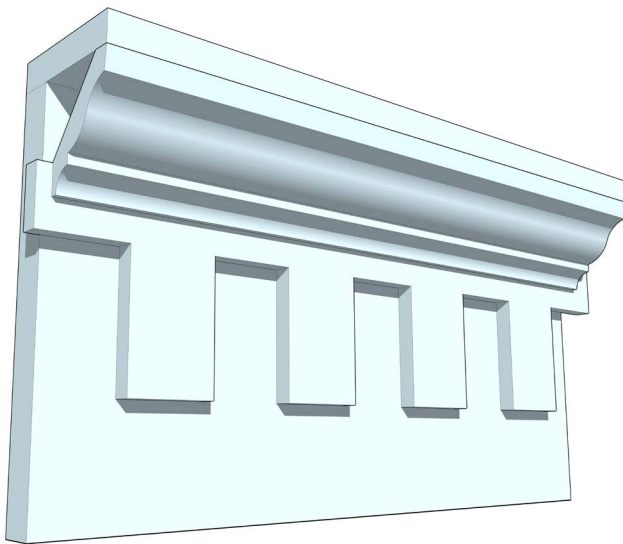

Figure 63 (i-63): Widely spaced PVC dentils with crown termination.



Figure 61: A close-up of dentils along eaves.



Figure 62: A dentil molding above a door.



Figure 64: Portico with widely spaced dentils with crown termination.



Figure 65: A close-up of widely spaced dentils with crown termination.

IV. COMPOSITE CROWN

Simple, top-of-wall trims exist that snap into the vinyl siding assembly. Designers can also develop an entablature combining various available millwork profiles.

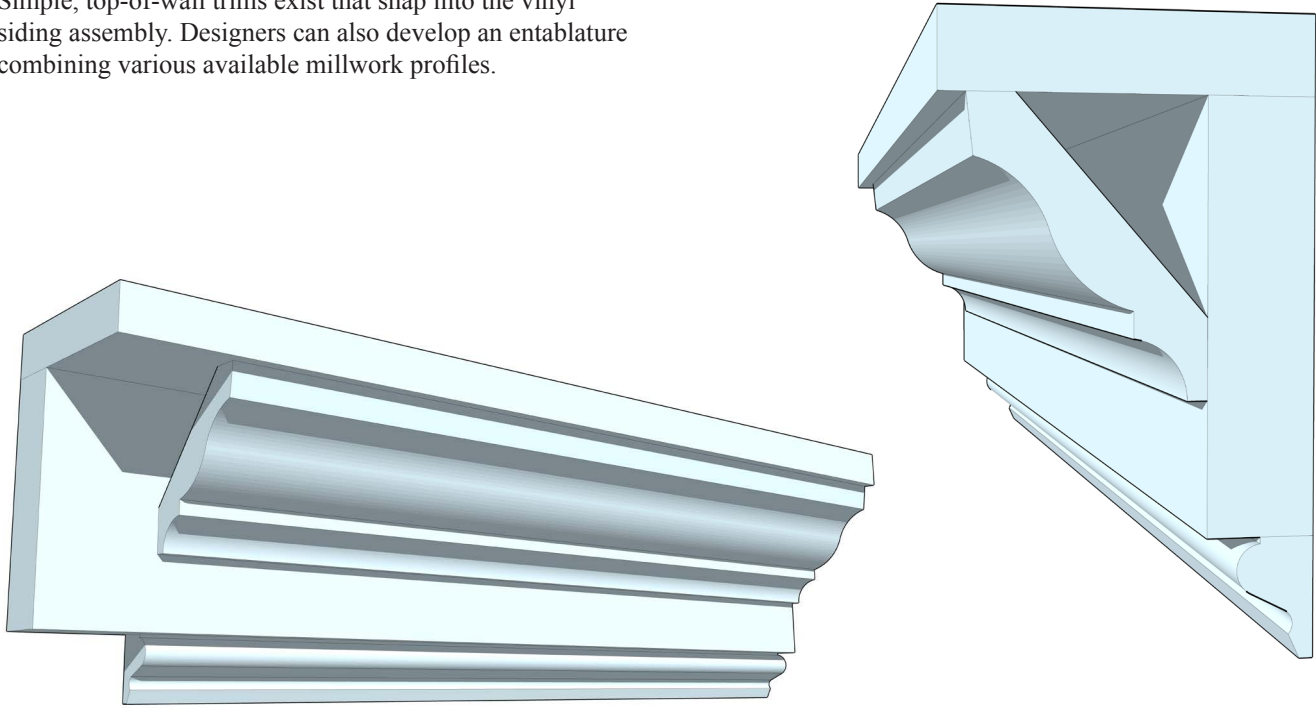

Figure 66 (i-66a, i-66b): At left, an entablature comprised, from the bottom, of cellular PVC bed molding, flat board, and crown molding trims; at right, the composite trims in profile.

V. KEYSTONES

Keystones represent an ornamental trim with a practical purpose. Placed at the center of an arch or lintel, the keystone hides the splice to adjust the head trim to the opening width.

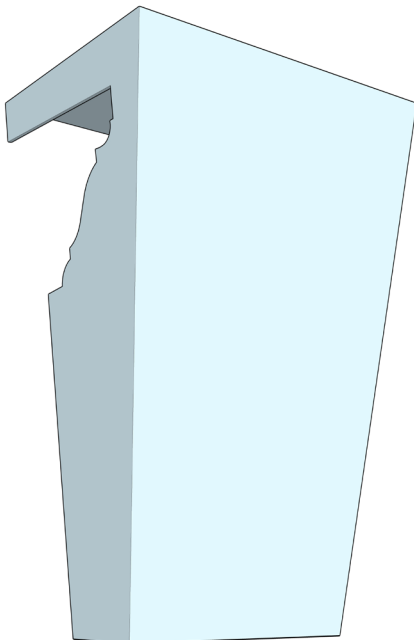

Figure 67 (i-67): Keystone.



Figure 68: Keystone at top of half-round window trim.

VI. PEDIMENTS

Classical pediments would be hard to assemble out of PVC, but manufacturers provide a range of preconstructed door and window terminations. Some come segmented to

accommodate different widths and hide the center splice with a keystone. Others come prefabricated to standard opening widths.

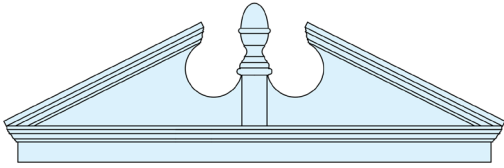

Figure 69 (i-69): Pediment with broken profile.

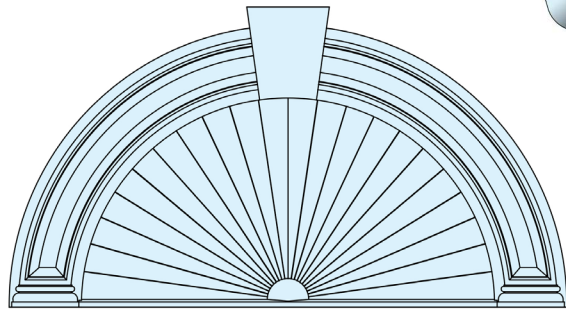

Figure 70 (i-70): Pediment with half-round profile and keystone.

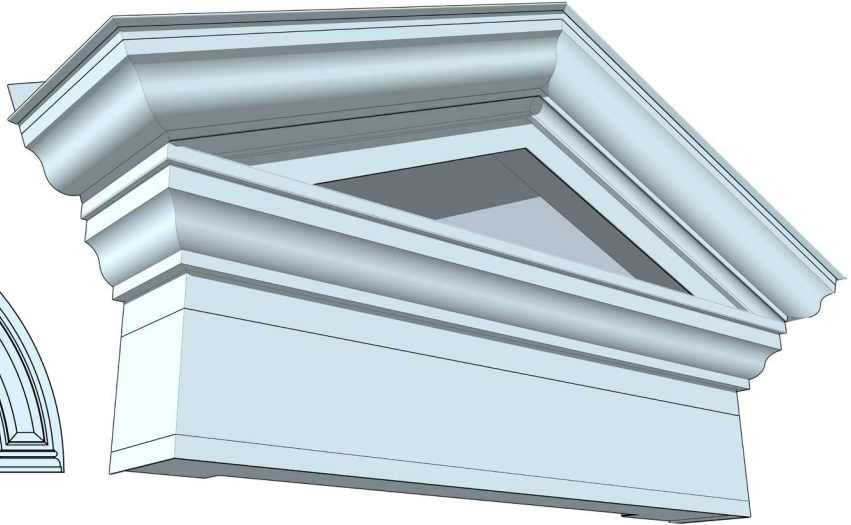

Figure 71 (i-71): Pediment lintel in perspective.

VII. COLUMNS AND POSTS

Major manufacturers and specialty shops fabricate a wide range of columns and posts for many types of architecture, from classical to Craftsman. These columns wrap around

structural posts to offer girth and decorative finishes. The column capitals and pediments adjust on-site to make sizing easy.

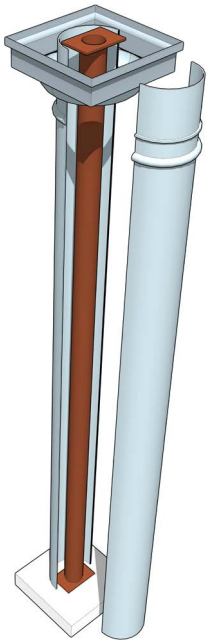

Figure 72 (i-72): Traditional column wrap.

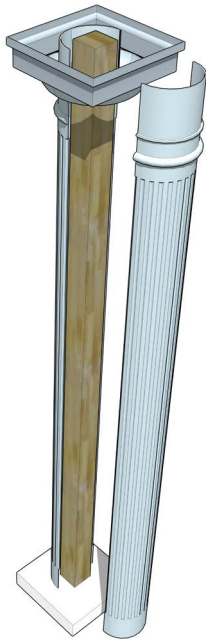

Figure 73 (i-73): Traditional fluted column wrap.

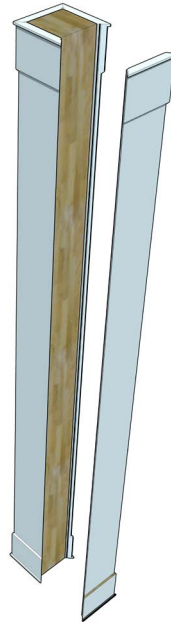

Figure 74 (i-74): Post wrap.

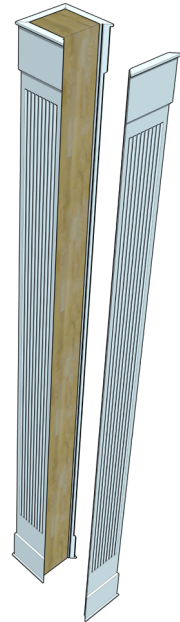

Figure 75 (i-75): Fluted post wrap.

Chapter 4

Workarounds

IN THIS CHAPTER

While manufacturers have created reasonable facsimiles of wood cladding, modern sidings designed to compensate for the shortcomings of wood come with limitations of their own. Wood shrinks and swells with changes in humidity, while architectural polymers expand and contract with temperature changes. To keep wood from decaying, swelling, and drying out, we use caulking and paint. Polymeric cladding systems require neither, but because PVC swells with heat and shrinks when cold, polymeric siding lengths require room for thermal movement. To allow for this, manufacturers have developed functional, pocketed trim and overlapping siding panels. However, this trim and the edge created by overlapping material do not exist in wood cladding. The presence of these material-specific characteristics in architectural polymers reveals that the installation is not “authentic” wood but an obvious simulation.

Just as caulking and spackle are used to compensate for the nail heads and joint gaps in wood siding, exacting designers can employ camouflaging techniques to control the aesthetic outcomes of vinyl material characteristics.

- | | |
|---|--|
| I. CAMOUFLAGING J-CHANNEL | VII. MITERED OUTSIDE CORNER OPTIONS |
| II. COMPENSATING FOR THIN MILLWORK EDGES | VIII. INSIDE CORNER OPTIONS |
| III. SIMULATING BUTT JOINTS | IX. ALTERNATIVES TO PENETRATION BOX-TRIM |
| IV. AVOIDING STACKED SEAMS | X. SOFFIT CONSTRUCTION |
| V. DIMINISHING WEDGE-SHAPED SHADOW LINES | XI. FASCIA CONSTRUCTION |
| VI. TRANSITIONING FROM HORIZONTAL TO VERTICAL | XII. ARCHITRAVE CONSTRUCTION |
| | XIII. EAVE RETURN |

I. CAMOUFLAGING J-CHANNEL

J-channel is used to provide an expansion pocket where polymeric siding butts into a rigid material, such as door and window trim. Typically, builders seek to obscure J-channel by using the same color as the siding. This approach fails to hide the detail and accentuates a component that does not exist in wood cladding. Instead, specify J-channel the same color as the trim so that the 1-inch-wide strip appears as a trim detail.



Figure 76: Vinyl window casing with an integrated pocket, or rabbet, to receive siding looks appealing when viewed from the street.

Certain trim profiles come with a pocketed profile that receives the siding. This integrated pocket relieves the need to scribe openings with J-channel. From the street view, looking at the trim face-front, the effect is satisfying, and some attractive casings exist.



Figure 77: J-channel resembles a traditional “back band” trim when matching the trim color rather than the siding color.



Figure 78: When J-channel matches the siding color, it adds a termination uncharacteristic of wood siding.

EXEMPLARY ARCHITECTURAL APPLICATION

In modern architecture, the material characteristics of vinyl such as stacked seams and J-channel do not produce a sharp contrast. Note how the dark color hides the seams and shadow lines. With darker colors now available and offering lifetime warranties against noticeable fading, this option provides a method to camouflage many material characteristics that some designers find objectionable.



Figure 79: If you could inspect this building, you would find stacked seams and J-channel on this contemporary townhouse. These elements do not distract from the architecture as similar details occur with metal siding, a style now trending in modern design.

II. COMPENSATING FOR THIN MILLWORK EDGES

Although manufacturers offer wider millwork profiles that look substantial from the front (see Figure 81), the material is too thin to mimic real wood trim when viewed from the side. On door openings, using pilasters and ornamental lintels can add girth. Insulated siding trims also offer thicker lineal boards that provide depth from the side view, but they still have a thin edge where pocketed to receive the siding.

Cellular PVC window trims come with rabbeted edges to receive the siding, and although thicker than the standard vinyl trims, these trims still do not offer sufficient girth to mimic wood trim overlay.

From a side view, the thickness of most plastic trim (at less than $\frac{1}{4}$ inch in vinyl and about $\frac{3}{16}$ inch in the case of cellular PVC) does not match a wood molding's $\frac{1}{2}$ -inch to $\frac{3}{4}$ -inch reveal. If this presents a problem, consider a built-up pocket made from two pieces of cellular PVC—a narrower board overlay with a wider board.

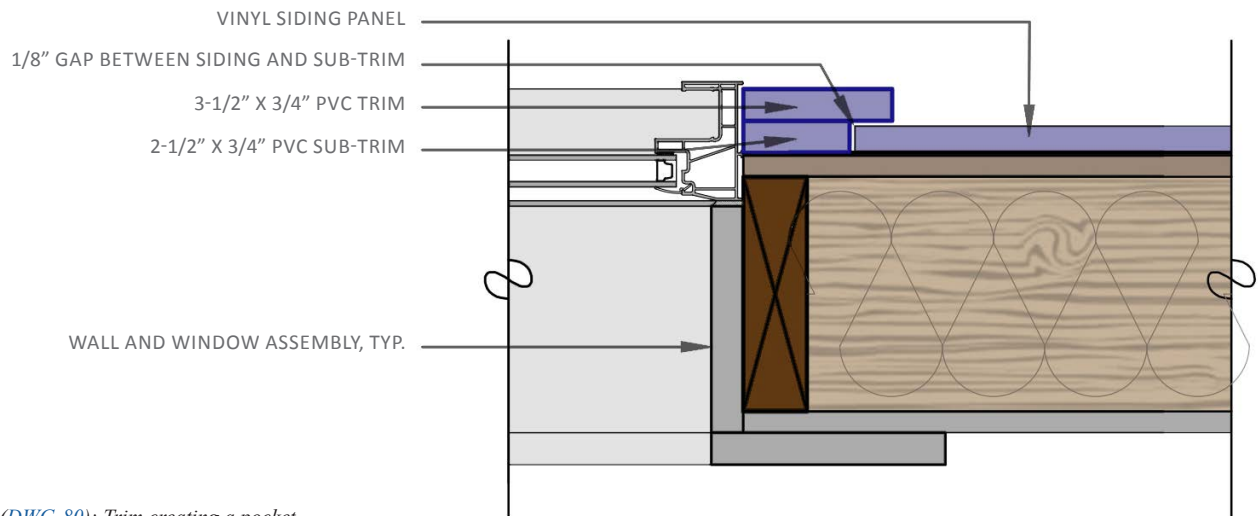

Figure 80 (DWG-80): Trim creating a pocket.



Figure 81: Cellular PVC trims with built-in J-channel (rabbeted pocket for receiving siding) may still appear too thin for a realistic perspective from the side.



Figure 82: Carpenters in historic buildings would sometimes lay trim over siding.

III. SIMULATING BUTT JOINTS

In addition to butting into trim, wood cladding panels butt into each other. The joint created by two pieces of wood siding generally requires caulking to seal. Polymeric cladding does not require caulking. To compensate for thermal movement, vinyl boards overlap about one inch. This overlap allows for expansion without the panels buckling and contraction without exposing a gap between seams. The overlap between siding panels creates a visible, slightly out-of-plane seam that some designers find objectionable. One way to mitigate this effect is to instruct installers to orient overlapping panels away from the dominant line of sight. Also, make sure to offset panels in random patterns to avoid a monotonous and more visible repetition on the wall. Stagger siding end-laps so that no two courses (rows of panels) will stack seams vertically unless separated by at least three runs. Lastly, vinyl siding comes in 12-foot, 16-foot, 20-foot, and even 25-foot-long boards. Keeping elevation widths within these dimensions and ordering longer material may avoid seams entirely.

Some vinyl siding profiles have more accented seams than others. Consider choosing flatter panels, such as beaded siding or a wider face clapboard with a flat profile to reduce the visibility of seams.

Other alternatives: 1) Some insulated siding materials offer a flat face with a low-profile overlap. 2) Cellular PVC siding panels interlock at the ends, creating a butt-joint appearance between panels. 3) Polyurethane (polyash) materials can butt to one another just as wood.

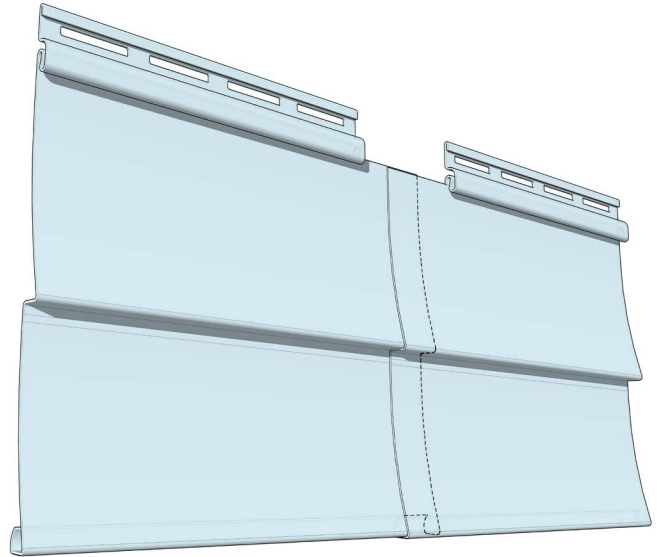

Figure 83 (i-83): Overlapping panels of at least 1 inch allow for expansion without buckling and contraction without exposing the seam.

EXEMPLARY ARCHITECTURAL APPLICATION

The most recent material development in the polymeric family comes with polyash. A polyurethane, glass fiber, and fly ash blend, polyash competes with fiber cement. Unlike fiber cement, this siding does not absorb moisture, so humidity will not freeze under the paint and cause spalling. Polyash resembles wood in workability because you can cut, miter, router, and tool it. Since the material has no expansion and contraction due to temperature or relative humidity, you can butt it up to adjacent boards and trim.

Figure 84 (i-84): This elegant Folk Victorian illustrates the application of polyash siding and trims. Note that the material, which incorporates fiberglass rather than cellulosic fiber, can run up against a roof rake without the 2-inch airspace required for fiber cement. If fire is a concern, polyash is among a very limited number of cladding products approved for all of California's Wildland-Urban Interface (WUI) zones—perhaps the most restrictive fire code in the United States.



IV. AVOIDING STACKED SEAMS

To facilitate installation, manufacturers make wide panels, generally 8 to 12 inches top to bottom, with several courses of siding molded into each. This multicourse arrangement gives rise to the terminology of “triple 3” or “double, 4-inch lap panel.” The multiple laps in a single siding panel create the appearance of stacked joints. Timber wood siding comes in single profile lengths, so installers will not line two-panel joints atop one another. Of note, many engineered wood products also have multiple-profile panels that create the same stacked-seam illusion.



Figure 85: Single panel of siding includes two-panel profiles so that the end laps create the illusion of stacked seams.

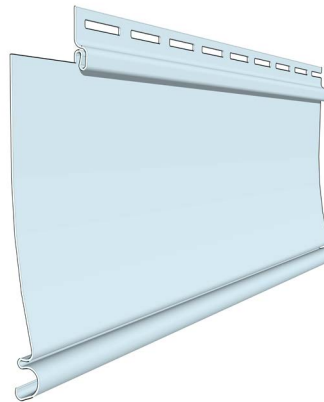

Figure 86 (i-7c): Some profiles come in single-face panels, such as this beaded siding.

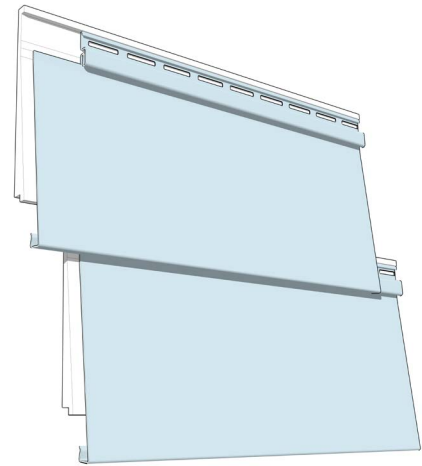

Figure 87 (i-6): Two single, 7-inch-wide clapboard panels offset.

To avoid stacked seams, consider dividing the façade into architectural sections that do not exceed the siding panels' length (12 feet, 16 feet, 20 feet, or 25 feet). Some siding profiles, such as beaded siding, wider clapboard siding, and some insulated products, come in single-face profiles so that no stacked joints will occur.

V. DIMINISHING WEDGE-SHAPED SHADOW LINES

Along with the need for pocketed trim to allow for thermal expansion of polymeric siding, a distinctive shadow line comes from the siding penetrating a pocket. Darker colors of siding create less noticeable shadow lines, while profiles with a wider face, such as Dutch lap, offer smaller, less visible shadow lines. Flat shapes, such as beaded siding and some wide, single-panel clapboard sidings, fit into the pocket tightly, producing almost no shadow line.

Keep in mind that in a traditional building, carpenters often overlapped trim on the siding to disguise the siding ends and avoid the task of multiple precision cuts. This face-planting of trim over siding created the same shadow lines as tucking polymeric siding into a pocket. The difference between the traditional trim overlay and polymers comes with the board thickness. To compensate for this, refer to Section II Compensating for Thin Millwork Edges.

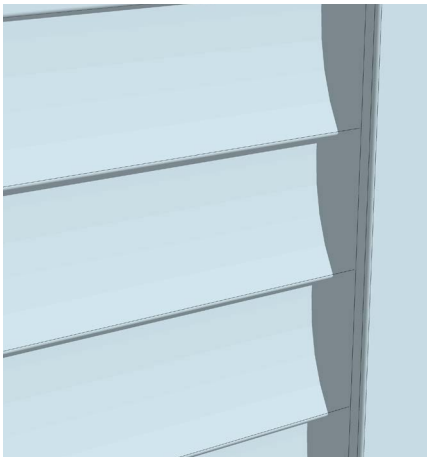

Figure 88 (i-88a, i-88b): At the receiving pocket, vinyl siding may create an unwanted shadow line. With Dutch lap, the shadow line is limited to the upper corner. Other profiles with minor shadow lines include beaded, vertical, flat, insulated clapboard, and some narrow, restoration-style clapboard.



Figure 89: The shadow line on wood siding is similar to the Dutch lap in vinyl.

VI. TRANSITIONING FROM HORIZONTAL TO VERTICAL

From a functional perspective, the correct method to transition from horizontal to vertical siding (or the reverse) involves a double J-channel with a Z-metal section to preserve the drainage plane.

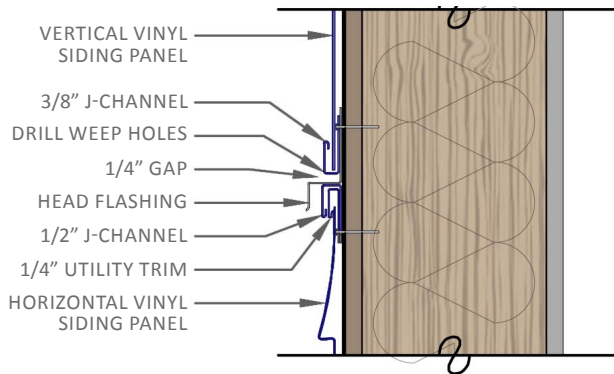

Figure 90 (DWG-90): Transition strip bridges horizontal to a vertical siding while preserving the critical drainage plane.

This transition, although practical, would not occur when constructing with wood. Instead, a band board would bridge the dissimilar materials. Vinyl bands, sometimes called “lineals,” provide a similar transition incorporating a double pocket (see Figure 93) or a single channel (see Figure 94). The lineal approach may require a starter strip or J-channel above, depending on the type of siding chosen.

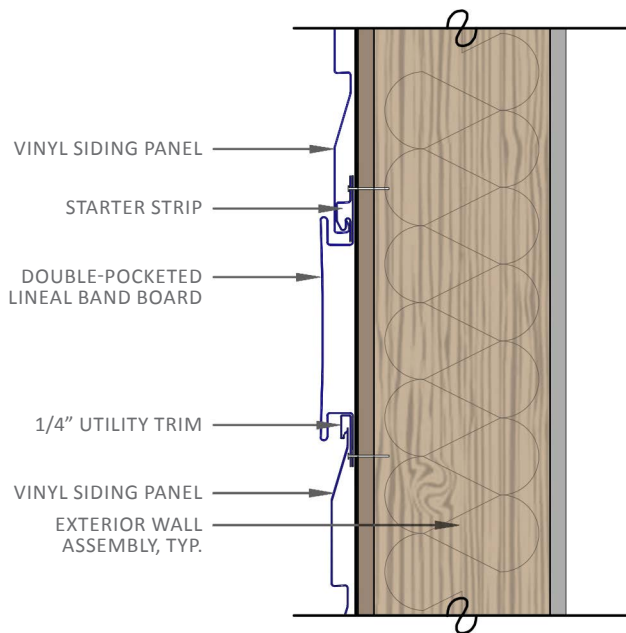

Figure 92 (DWG-92): Detail of a double-pocketed band board. The transition may require a starter strip in the first course. Starter strip is often a needed accessory used at the bottom of a siding to hold it in place. Note that this profile offers a thicker board edge than other pocketed trims.



Figure 91: A typical transition between siding on the body of the house, in this case board-and-batten, and another siding on the gable end, in this case vinyl shake. The transition is mediated by a horizontal band. To ensure continuous drainage and material attachment to the structure, the installer must use the correct functional trim.

Band boards come in sizes ranging from 3.5 inches to 6 inches. A J-channel on top to receive the cladding over the band can appear as the drip edge or sill often installed over a wooden band.

Alternatively, use a double-pocketed band, such as shown in Figure 93. In some cases, the new material may require a starter strip in the first course.

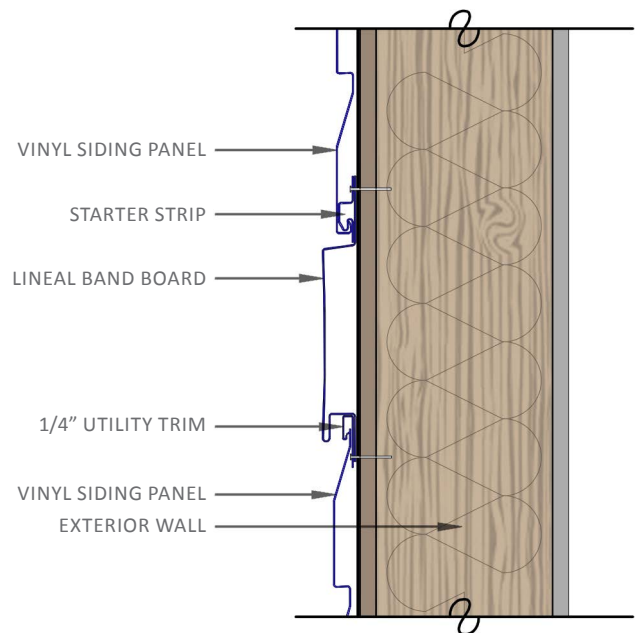

Figure 93 (DWG-93): The lineal or band board provides an elegant transition when switching from one type of siding to another, such as from horizontal to vertical or shake.

VII. MITERED OUTSIDE CORNER OPTIONS

None of the synthetic sidings, except polyash, make a true mitered corner. Polyash material is toolable, and hence installers can cut a miter into the board. Most other synthetic siding offers an outside corner post. These outside corner posts come in various sizes, from 3.5 inch to 6 inch, and in treatments including flutes, quarter-rounds with accent color inserts, and straight or simple beads. Shake siding does offer a corner that appears as mitered cedar, although the material protrudes from the siding plane and has an artificial appearance. Some cellular PVC shake makes a realistic and satisfactory corner (see Figure 96).

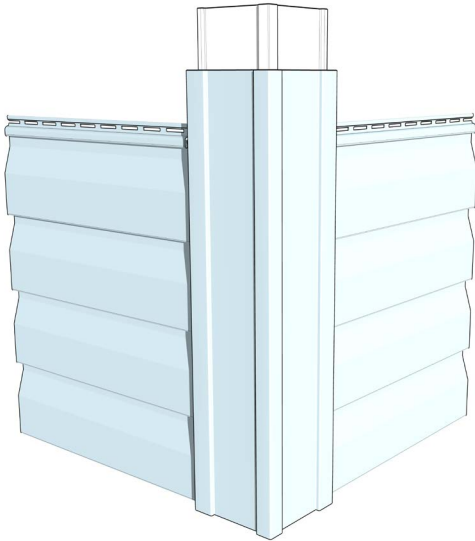

Figure 94 (i-94): Vinyl outside corner post with a simple but elegant profile.



Figure 95: A tooled mitered corner in polyash.



Figure 96: Mitered corner in cellular PVC shake.

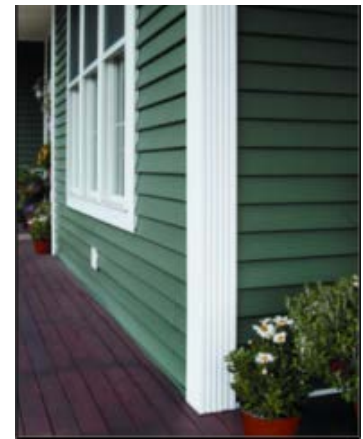

Figure 97: Fluted corner post.



Figure 98: Mitered corner in polypropylene shake.

VIII. INSIDE CORNER OPTIONS

Although designers sometimes critique the standard vinyl inside corner, it represents the wood version well, with only some additional width (see Figures 100 & 101). The designer must specify that the inside corner color should match the siding to avoid an odd highlight.

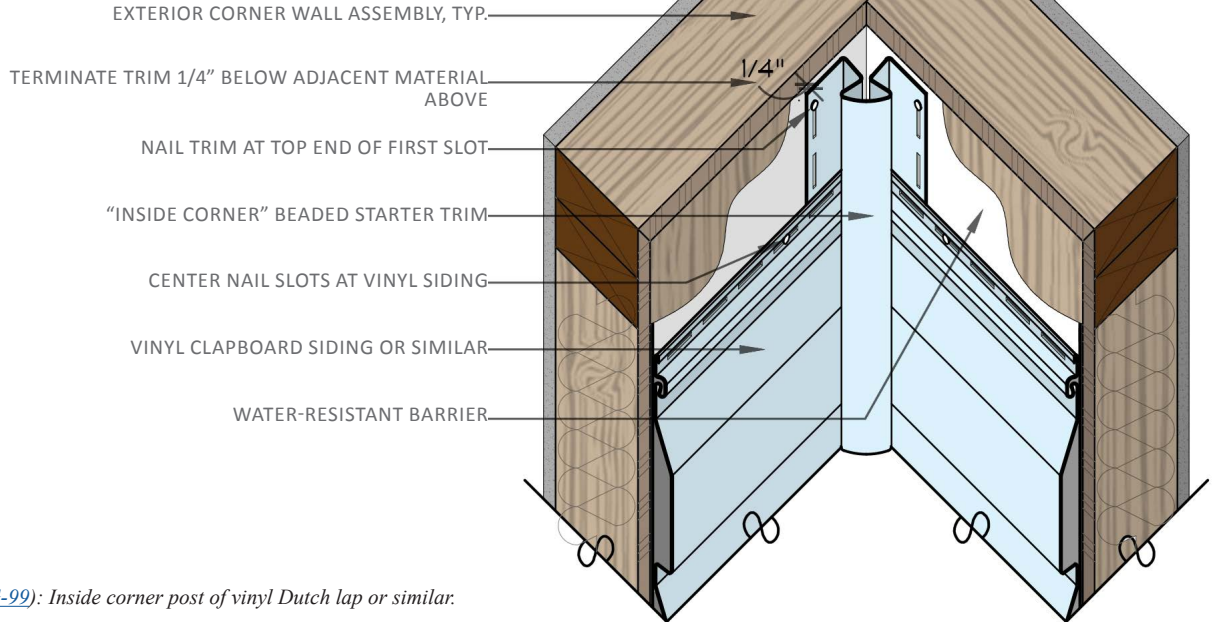

Figure 99 (DWG-99): Inside corner post of vinyl Dutch lap or similar.

Another option is to use a lineal installed vertically, as shown in Figure 102.



Figures 100 & 101: At top, standard vinyl inside trim; at bottom, traditional wood inside trim. Specify inside corner trim with the same color as the siding.



Figure 102: A wide lineal installed vertically can create a handsome inside corner post.

IX. ALTERNATIVES TO PENETRATION BOX-TRIM

To provide a receiving pocket for the siding, manufacturers provide specialty trim for penetrations through siding, such as hose bibbs, to avoid crushing the wedge-shaped siding angle. These boxes offer a flat base and J-channel frame. Like other accessories designed to accommodate vinyl material requirements, these boxes do not occur on a wood

siding installation. Avoid these boxes by breaking the siding at the penetration location – whether a hose bibb, an AC line, or other – and then scribe an oblong slot into either end of the adjoining panels and slide these under the penetration. A common pipe escutcheon will then cover the hole.

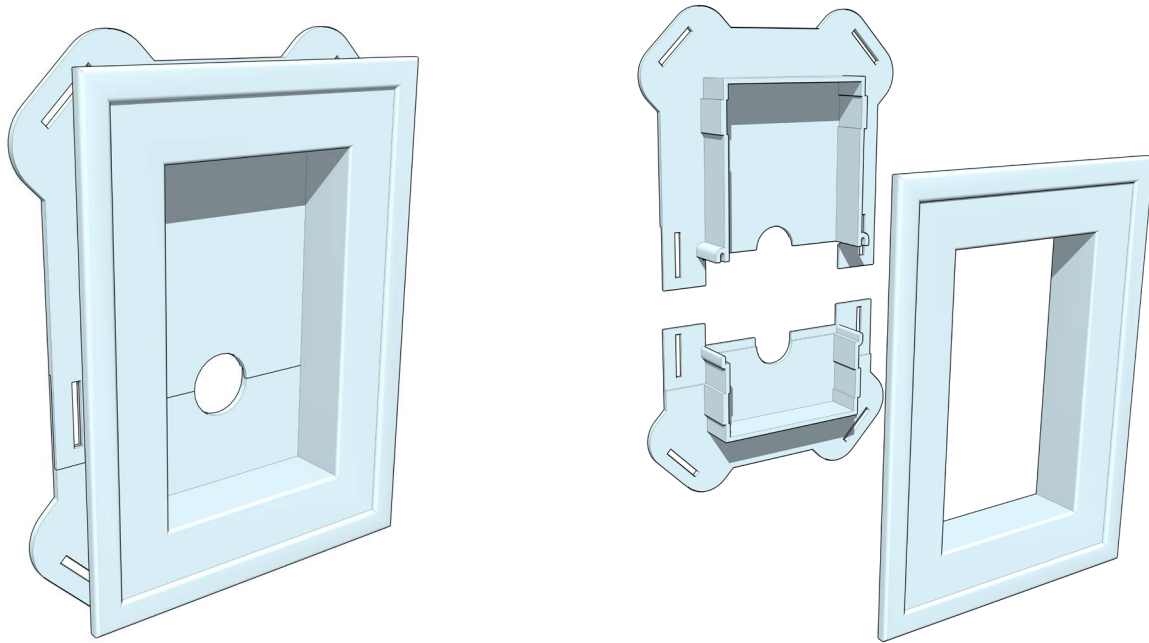

Figure 103 (i-103a, i-103b): At left, a box-out; at right, box-out exploded.

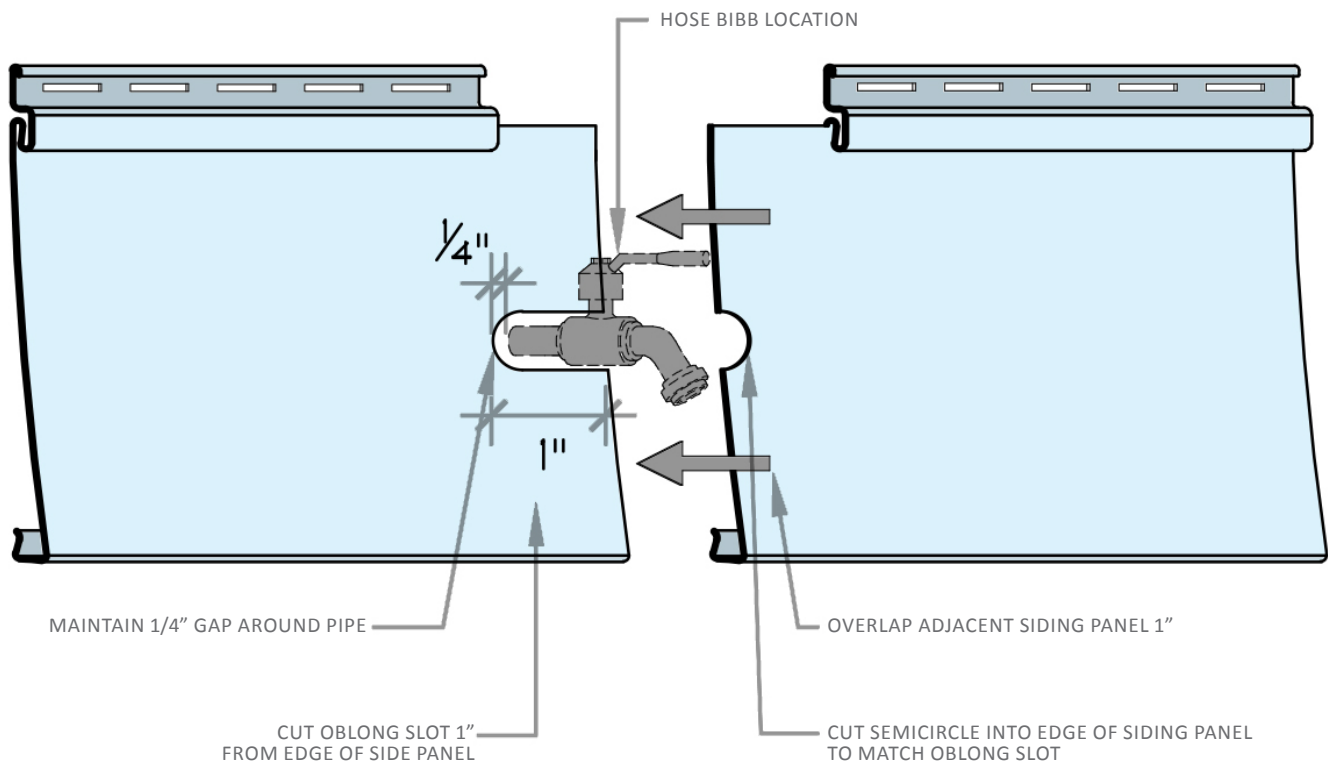

Figure 104 (DWG-104): Hose bibb cut-out.

X. SOFFIT CONSTRUCTION

The advent of truss roofs changed the way builders construct soffits and trim rakes and terminate eaves. The area where the roofline meets the wall distinguishes the conventional from a traditional building since the truss ends, or “rafters,” only span 3.5 inches in width. Only with difficulty can builders create the appearance of exposed rafter tails. In addition, because roofs require convection (ventilation) to cool the attic, builders ameliorate soffits for ventilation by either perforating them with soffit vents or installing vinyl soffits with factory perforations.

Manufacturers also offer a beaded soffit with vent holes hidden within the grooves. These do not provide the same level of exposure to air, although they still qualify as “continuous” ventilation. More discrete than the fully perforated soffits, they remain better looking.

When constructing a hip roof, a traditional soffit will miter at each corner. Vinyl requires a receiver, so the miter is accomplished with a double receiver (also known as a T-bar or H-bar).



Figure 106: Look carefully and the perforations in the grooves of this premium vinyl soffit are just visible.

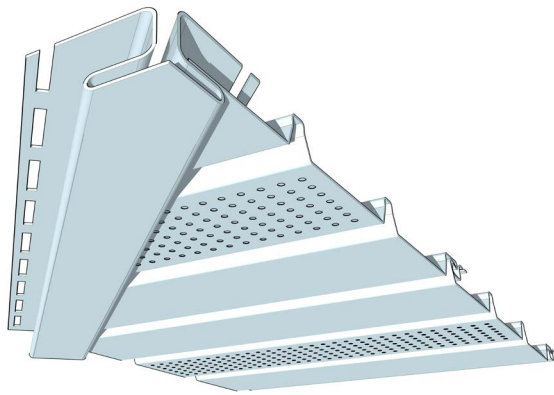

Figure 105 (i-105): Trim for outside corner of soffit.



Figure 107: Perforated vinyl soffit.

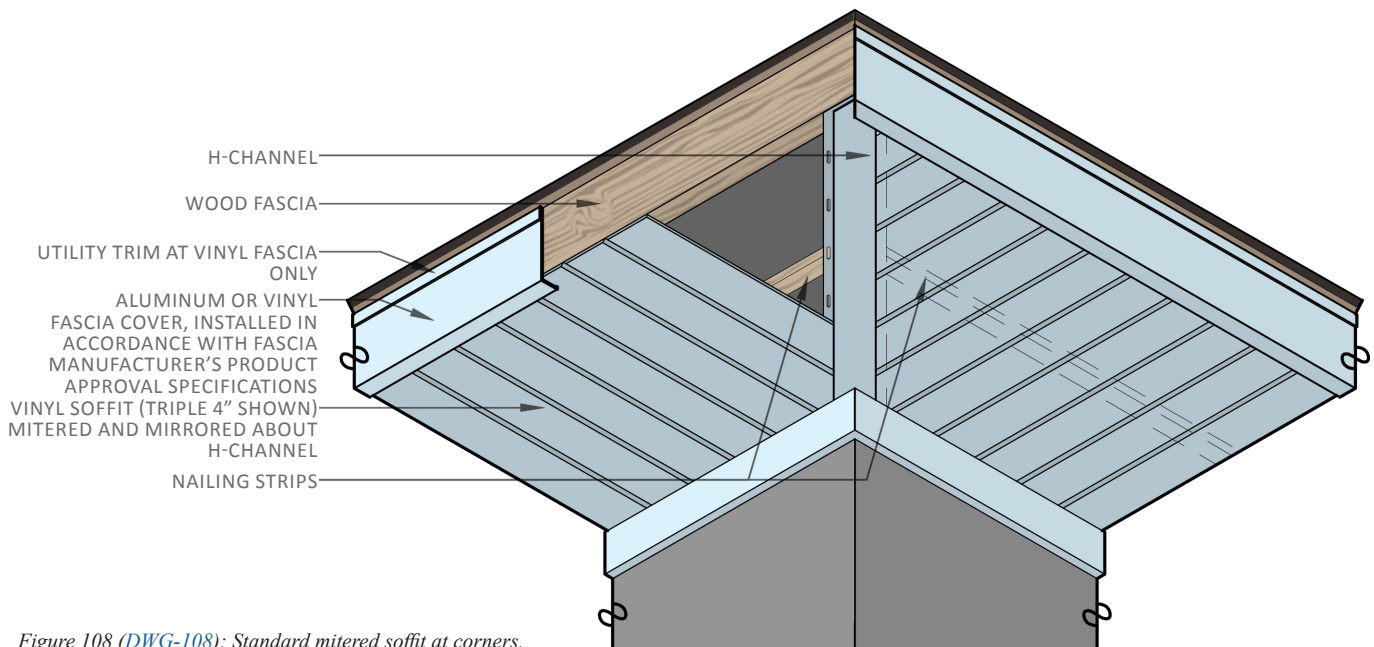

Figure 108 (DWG-108): Standard mitered soffit at corners.

XI. FASCIA CONSTRUCTION

The cornice, commonly called a "fascia board," may have a vinyl or aluminum cover. This fascia cover may also receive a vinyl or aluminum gutter.

Whether choosing a vinyl or aluminum fascia cover, it must slip into a utility trim on top to fasten securely. Instead of nails, the fascia friction-fits into this utility trim with perforations in the surface created by the "snap-lock punch" tool (see Figure 36).

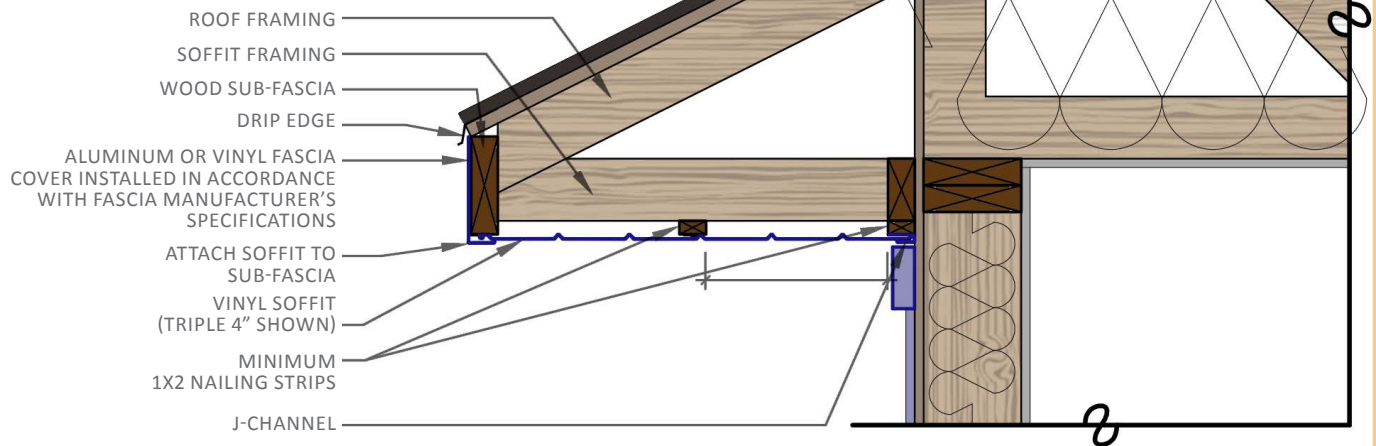

Figure 109 (DWG-109): Fascia and soffit detail.

EXEMPLARY ARCHITECTURAL APPLICATION

Torti Gallas + Partners designed the Concept House under the Partnership for Advancing Technology in Housing. Constructed by Fernando Pagés, the house won the Best Green Built Demonstration Home Award from the National Association of Homebuilders. The deep red insulated vinyl siding was chosen because the manufacturer offered the longest available material warranty for any exterior cladding.



Figure 110: The PATH Concept House designed by Torti Gallas + Partners.

XII. ARCHITRAVE CONSTRUCTION

Trimming out the architrave to the soffit can add an important distinction to a vinyl-clad wall that also yields the benefit of securing the top panel. This top panel, the soffit, and fascia cover represent the most vulnerable areas to the wind. Study the detail in Figure 112 to see the “two-piece receiver” that serves as utility trim to lock the top panel (see Figure 36) and a receiver to snap in the “two-piece” cover. This cover appears as a cavetto or bed molding under the soffit. This molding offers a more elegant appearance than simply jamming a narrow strip of cut siding under the soffit. All the terminations available under soffits also operate beneath rakes.

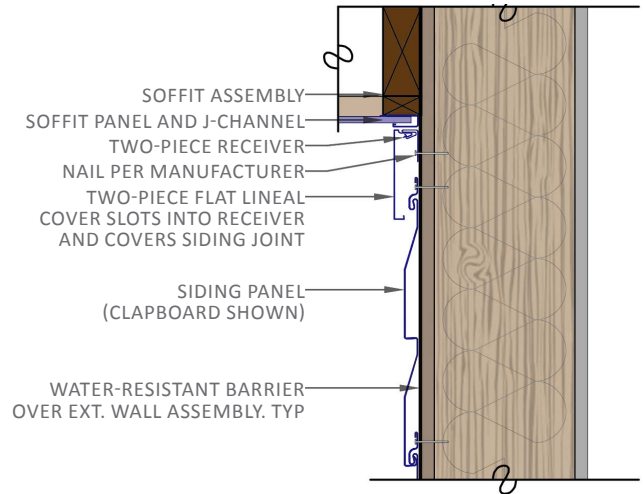

Figure 112 (DWG-112): Top-of-wall termination.

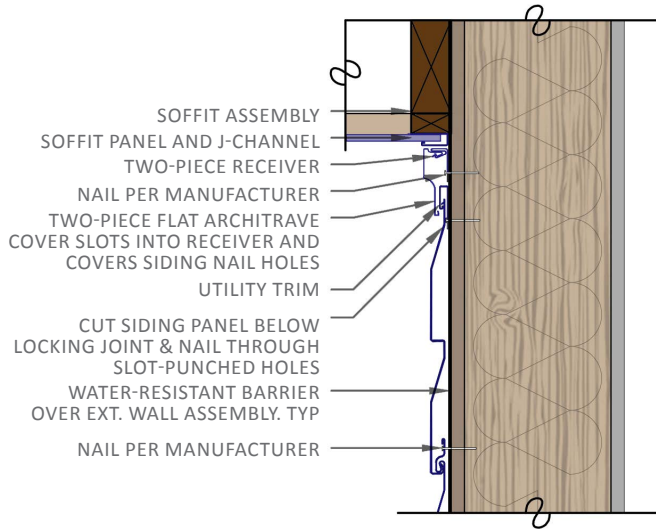

Figure 111 (DWG-111): Top-of-wall architrave.

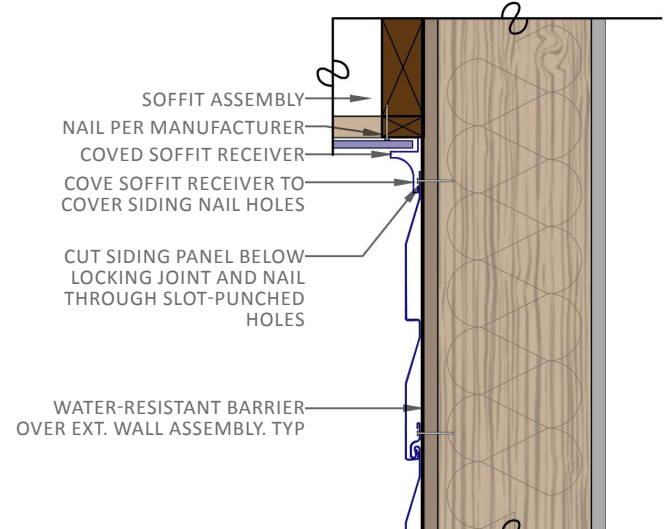

Figure 113 (DWG-113): Under soffit, articulated cove.

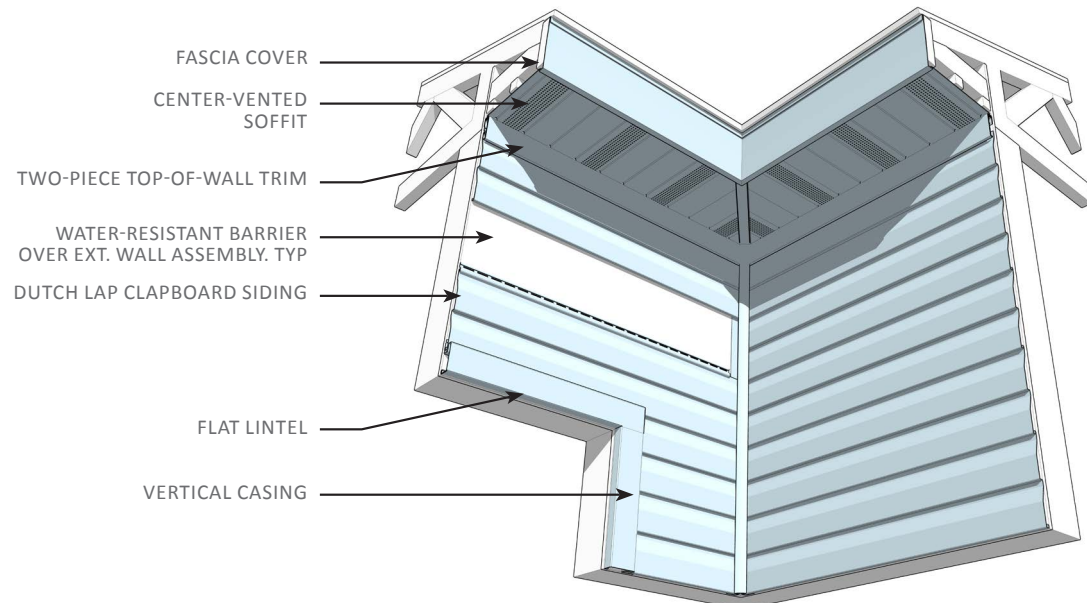

Figure 114 (i-114): Top-of-wall construction.

XIII. EAVE RETURN

One of the distinguishing characteristics of a modern residential building is the eave return. Instead of a return, builders typically create a boxed triangle. Easier to construct, it does not provide an elegant termination to the roof and distinguishes the building as a vintage nouveau.

While slightly more complex and difficult to build, the true eave return pays tribute to the classic entablature. The builder can reproduce the return using a combination of polymeric moldings.

Several simple alternatives exist for finishing. The most common is with a standard soffit and aluminum fascia.

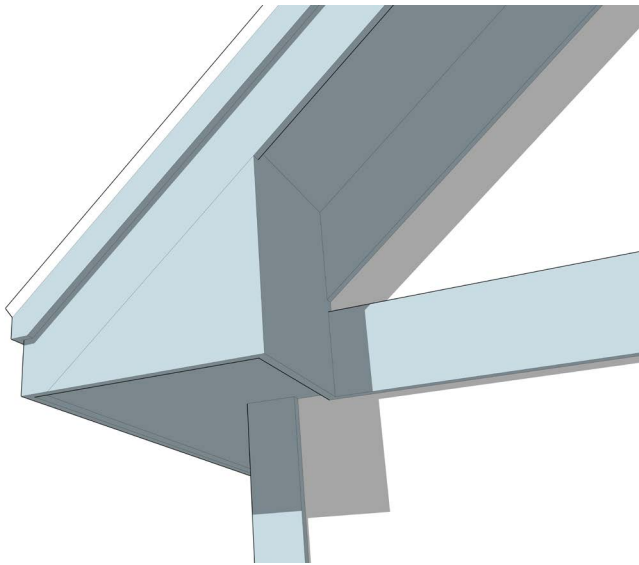

Figure 115 (i-115): The most common way to terminate the eave is now the boxed end, or "pork chop" eave.

Aluminum is easily bent and cut to shape on site. However, the oil canning that results on the surface can detract aesthetically. Vinyl fascia does not have the oil canning issue, and it becomes easier to ornament with cellular PVC moldings. With many moldings available, this material affords the possibility of elaborate ornamentation.



Figure 116: Affectionately known as the "pork chop," this style of eave termination came courtesy of truss roof construction as a way to finish the end of the rake at the soffit corner.

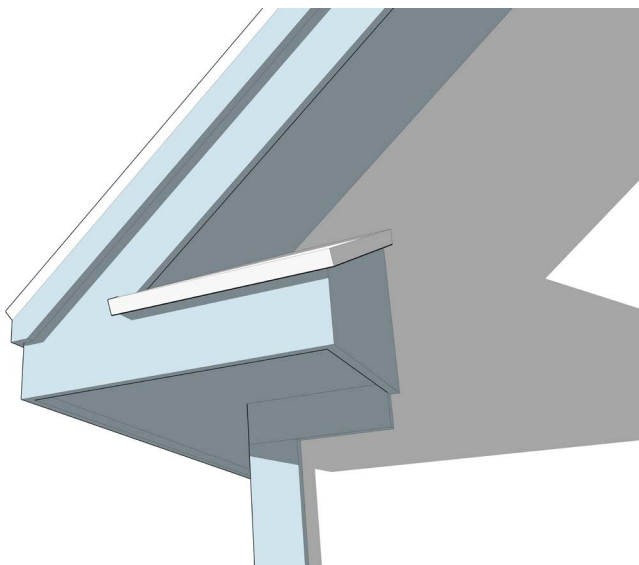

Figure 117 (i-117): A simple eave return that suggests the traditional detail.



Figure 118: The eave return, shown here with vinyl siding, soffit, and aluminum fascia, terminates the roofline with a more accurate, traditional detail.

Appendixes

APPENDIX LINKS

The forms in this section are provided as hyperlinks to editable Word documents that you can tailor to your project requirements. Click the hyperlink for Appendixes 1-5 to download as Word DOC CSI Format Master Specification.

APPENDIX 1.

[SECTION 07 46 33 VINYL SIDING](#)

APPENDIX 2.

[SECTION 07 46 33 INSULATED VINYL SIDING](#)

APPENDIX 3.

[SECTION 07 46 33 POLYPROPYLENE SIDING](#)

APPENDIX 4.

[SECTION 06 65 00 CELLULAR PVC TRIM](#)

APPENDIX 5.

SECTIONS 01 35 63 / 01 81 13 / 0111
SUSTAINABLE DESIGN REQUIREMENTS
SUSTAINABILITY CERTIFICATION PROJECT
REQUIREMENTS (coming soon)

APPENDIX 6.

Please find the Vinyl Siding Environmental Product Declarations at:

www.vinylsiding.org/why-vinyl/sustainability

APPENDIX 7.

Please find sustainability resources at:

www.vinylsiding.org/why-vinyl/sustainability

APPENDIX 8.

Please find building code resources at:

www.vinylsiding.org/industry-professionals/building-officials

APPENDIX 9.

[Model community design code for vinyl siding](#)

VSI is a partner with the Congress for the New Urbanism, a non-profit organization promoting the development of walkable urban communities, and member of The American Institute of Architects.



**The American
Institute
of Architects**

This guide is intended to serve as a resource for the product specification of architectural polymers. By putting the power of good design details and recommended installation practices within easy reach of the Architect, this effort aims to provide full control of the design's aesthetic outcome.

Other Books In This Series:

ARCHITECTURAL DESIGN FOR TRADITIONAL NEIGHBORHOODS

Available at bookstore.vinylsiding.org

Fernando Pagés Ruiz, principal, Artisan LTD, is a pocket-neighborhood developer in Colorado and the author of *Building an Affordable House: Trade Secrets to High-Value, Low-Cost Construction*, published by the Taunton Press. He is a former editor of *EcoHome Magazine* and regular contributor to various construction magazines.

PEL•ONA Architects & Urbanists was founded by Ronnie Pelusio and Korkut Onaran. Located in Boulder, Colorado, their atelier applies timeless values to architecture and sustainable urbanism.

Dana Johnson is a native of Fort Collins, Colorado, and received his B.A. in Environmental Design from the University of Colorado at Boulder, he also holds an A.A.S. in Architectural Engineering Technology.

Peter Chapman is senior editor at the Taunton Press in Newtown, Connecticut.

Vinyl Siding Institute (VSI) is the trade association representing the manufacturers of polymeric siding and trim products in North America. VSI and its members are committed to the principles of New Urbanism and traditional neighborhood development (TND) and to furthering these concepts. They are involved in the Congress for the New Urbanism and work toward innovations that meet the needs of new urbanists, town founders and architects involved in this vital movement. **For more information on VSI, please visit vinylsiding.org.**

